

DL-100

Economic Bench Scale

- Battery Operated
- Easy to Read LCD Display
- Auto Power Off



ISO 9001 certified

CAS
S · C · A · L · E

DL-100 Economy Bench Scale

FEATURES

- Battery Operated.
- Standard AC Adapter.
- On/Off, Zero, Tare, Counting, and Hi/Lo Functions.
- Easy to Read LCD Displays.
- Auto Span Adjustment.
- Auto Zero Tracking.
- kg / lb Switchable.

SPECIFICATIONS

Model	DL-100
Weighing Capacity	200 lb x 0.1 lbs (100 kg x 50 g)
Measurement Type	Load Cell
Display Type	LCD (6 Digit)
Power Source	DC 9V (1.5V x 6EA) / AC Adapter
Power Consumption	1W (Adapter)
Operating Temperature	- 10°C ~ +40°C (14°F ~ 104°F)
Weighing Pan(inch / mm)	13.6(W) x 18.3(D) / 345(W) x 465(D)
Dimensions (inch / mm)	16.5(W) x 25(D) x 28.7(H) / 420(W) x 635(D) x 730(H)
Product Weight	35.3 lb / 16 kg

DIMENSIONS

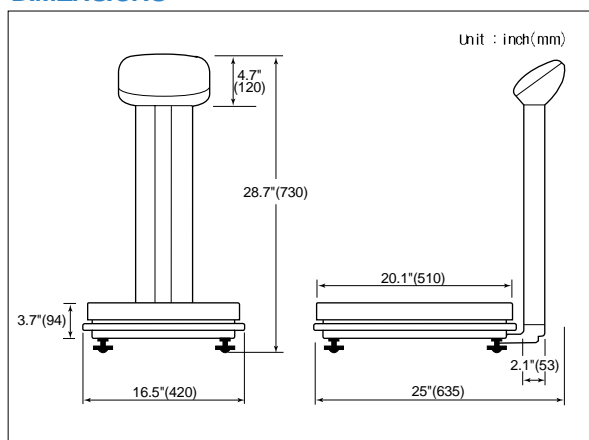

DISPLAY & KEY BOARD



KEY FUNCTION

- Mode Functions
 - kg / lb Conversion Mode
 - HI / LO Mode
 - Counting Mode



CAS USA Corporation

NJ OFFICE
 99 Murray Hill Parkway
 East Rutherford, NJ 07073
 Tel: (201) 933-9002
 Fax: (201) 933-9025

<http://www.cas-usa.com>

CA OFFICE
 733 S. State College Blvd #98
 Fullerton, CA 92831
 Tel: (714) 870-1286
 Fax: (714) 870-1167



Specifications are subject to change for improvement without prior notice.

2000. 7