



**LP600
Users Manual**

Manual #: 7005056-E

Table of Contents

DECLARATION OF CONFORMITY	4
INTRODUCTION	5
SPECIFICATIONS	6
<i>Controls</i>	6
<i>Electrical</i>	6
<i>Performance</i>	6
<i>Environmental</i>	7
<i>Physical</i>	7
<i>Radio (optional)</i>	7
SCALE OPERATIONS.....	8
OPERATIONAL OVERVIEW.....	8
DISPLAY DESCRIPTION.....	8
CONTROLS	9
<i>ON / OFF</i>	9
<i>PRINT / ACCUMULATE</i>	9
<i>LOCAL / TOTAL</i>	10
<i>ZERO</i>	10
TOTALIZING SETUP.....	12
SERIAL OUTPUT SETUP	13
ON-DEMAND	13
CONTINUOUS	14
<i>Data Format</i>	14
ACCUMULATING PRINT.....	14
WEIGHING PROCEDURES	15
USING ACCUMULATED TOTAL	16
ACCUMULATING PRINT AXLE	16
ACCUMULATING PRINT STANDARD	17
ACCUMULATING PROCEDURE:.....	18
MODE MENU	20
MODE MENU	20
SETTING THE MODE MENU PARAMETERS	21
CALIBRATION.....	24
PROCEDURE: CALIBRATION (VERIFICATION)	24
PROCEDURE: CALIBRATION (ADJUSTMENT)	27
<i>Calibration Enable Jumper</i>	27
<i>Multiple Corner Adjustment</i>	28
<i>Single Corner Adjustment</i>	30
<i>Calibration menu</i>	31
SETTING THE CALIBRATION PARAMETERS	32
<i>Multiple Graduation Break Points</i>	32
WEIGHT CALIBRATION.....	34
TROUBLESHOOTING	36
PROBLEM TABLE	36

ERROR MESSAGES	37
DIAGNOSTIC TESTS AND VOLTAGE MEASUREMENTS.....	38
<i>Charger voltage</i>	38
<i>Lamp</i>	38
<i>Keys</i>	38
<i>Power down shutoff</i>	38
<i>Load Cells</i>	38
CALIBRATION "STEP" CODES	40
REPLACEABLE PARTS	41
CONNECTOR	42
HOW TO REACH INTERCOMP	43

"This document is the property of Intercomp Co. It contains material and information that is confidential and protected under federal and/or state trade secret, unfair competition, and copyright law. Any reproduction, use or disclosure without written permission from Intercomp Co. is prohibited".

Declaration of Conformity



We, Intercomp Company
3839 County Road 116
Medina, Minnesota 55340 USA

Declare under sole responsibility that the (LP600) Wheel Load Scale to which this declaration relates meets the essential health and safety requirements and is in conformity with the relevant EC Directives listed below using the relevant section of the following standards and other normative documents.

1999/5/EC - Essential requirements and other relevant requirements for Radio and telecommunications terminal equipment
2001/95/EC - General product safety
2002/96/EC as amended by **2003/108/EC** - WEEE directive
2004/108/EC – EMC Directive
2006/66/EC - Batteries and accumulators directive
2006/95/EC – Low Voltage Directive
2009/23/EC - Non-automatic weighing instruments
2009/125/EC - ECO Design – Recast
2011/65/EU - RoHS – Recast

EN 55011:2009, Class B – Limits and methods of measurements of electromagnetic disturbance characteristics of industrial, scientific and medical (ISM) radio frequency equipment.

EN61000-6-1:2007 - Generic standards, Residential, commercial and light industry environment.
EN61000-6-2:2007 - Generic standards, Immunity for industrial environments.
EN61000-6-3:2007 - Generic emission standard, Domestic, commercial and light industry environment.
EN 61010-1/IEC 1010-1 - Safety requirements for electrical equipment for measurement, control and laboratory use.

This product complies with all safety-relevant provision referring to protection against electrical hazards and other hazards, such as mechanical hazards, fire hazards, noise and vibration. The safety issues of this measurement equipment have been evaluated under the self-certification provisions of the relevant directives.

EN 45501:1992 AC:1993 - Specification for metrological aspects of non-automatic weighing instruments
PL 05 004 – Certificate of EC type approval for LP600.

The related technical construction files are held for inspection in the U.K. at Intercomp Europe Limited. The CE mark, Green M and WEEE marks must be affixed as required in the directives.

A handwritten signature in black ink that reads 'Mark Browne'. The signature is written in a cursive style with a small 'B' and 'r' that are particularly prominent.

Mark Browne / Quality Manager
13 July 2014

Introduction

This operations manual describes the Intercomp Model LP600 platform specifications, detailed operating procedures, and calibration.

This manual is separated into several sections, each containing information on a different aspect of the platform. The specifications outline the design parameters for the scale. The detailed operation section outlines the correct use of the scale for most applications. The calibration section explains how to set the platform's adjustments.

Caution: Your LP600 scale is covered by a one year warranty and should be referred to the factory for maintenance within the warranty period. Attempts to make any extensive repairs within the warranty period may invalidate the warranty. If repairs are needed after the warranty period, only qualified technicians should attempt such repairs.

Features

lb or kg programmable readout.

Ability to display total weight.

Accumulating total function.

Auto zero tracking automatically corrects zero-weight display shifts.

5½ digit, 1 inch LCD readout, with automatic back lighting.

5-15 VDC and 120 VAC 60 Hz power sources standard.

RFI/EMI protection.

Low battery detection with automatic shutoff to protect batteries.

Built-in self-diagnostics to check: Load cells, Memory, Display, AD converter, and Power supply.

Weigh pads manufactured from high strength aluminum alloys.

OPTIONS

Carrying cases for weigh pads and platform scales.

Radio for wireless operations

Data Acquisition Computer

Specifications

Controls

General	On/Off, Print/Accumulate, Local/Total, Zero
Display	5 1/2 digit, 1 inch liquid crystal display (LCD), with automatic back lighting.
Indicators:	local weight, total weight, accumulated total weight

Electrical

Power Source	Dual power solar and batteries. Available direct power 5 - 15 VDC, 100-240VAC when using charger cable.
Direct Power Charging Voltage	9 - 15 VDC.
Batteries	4-AA size NiMH recommended. For emergency use, off-the-shelf alkalines can be used for a short duration of about a week or less. Extended use beyond this could result in battery leakage and corrosion damage on the battery contacts in the scale.
Cable Charging Current	50 mA.
Solar Power Current	25 mA with full sun.
Battery Life	Radio off: 250 hours plus solar power. Radio on: 200 hours plus solar power. With daytime outdoor use, the solar power allows the scale to last a full year without requiring direct power charging. It is recommended to change the batteries on an annual basis. Note that the amount of sunlight and/or geographic position can affect the solar benefit. NOTE: For special setups that require a scale wireless 'host', that scale's battery life is 40 hours.
Filtering	Adjustable averaging up to 30 seconds.
Auto-Zero	Satisfies all HB-44 requirements.

Performance

Speed	4 display updates per second
Accuracy	$\pm 1\%$ of reading or \pm display graduation, whichever is greater.
Calibration interval	Twelve months recommended

Environmental

Humidity	10 to 95% Non-Condensing.
Temperature	Operating: -28 C to +65 C. / -20 F to +150 F.
	Storage: -40 C to +75 C. / -40 F to +170 F.
Ingress Protection	IP67
EMI/RFI	Meets Mil Spec 461

Physical

Dimensions	Platform: 22.5" X 15.0" X 1.5" / 569 X 381 X 38 mm Overall (w/ skid guard): 33.25" X 18.5" / 845 X 470 mm Overall (no skid guard): 33.25" X 16" / 845 X 406 mm
Weight	w/ skid guard: 51 lb / 23 kg No skid guard: 47 lb / 21.4 kg

Radio (optional)

Radio frequency	ISM 2.4GHz, 802.15.4
License requirements	None. Pre-approved US/FCC, CAN/IC, EUR/CE
Range	200' / 60m indoor, 300' / 90m line of sight
Batteries (AC-PDA-RF only)	4-AA size alkaline or NiMH rechargeable
Battery life (AC-PDA-RF only)	36 hours using NiMH 2500 or alkaline

* Radio notes: Frequency: ISM 2.4GHz (2.400GHz - 2.483GHz), with 12 channels (CH 1-12) within that range with each center frequency = 2405MHz + (CH * 5) MHz. Power output 63mW (18dBm), 10mW (10dBm) for international variant. Antenna is internal surface mount with -1.5dbi gain, omni-directional.

	<p>WARNING: To satisfy FCC RF exposure requirements for mobile transmitting devices, a separation distance of 20 cm or more should be maintained between the antenna of this device and persons during device operation. To ensure compliance, operations at closer than this distance is not recommended. The antenna used for this transmitter must not be co-located in conjunction with any other antenna or transmitter.</p>
---	---

Scale Operations

Operational Overview

The control panel for the weighing platform is in the front section of the pad, along with the electronics of the system. The control panel has a liquid crystal display (LCD) screen and several control switches.

Display Description

The display is a Liquid Crystal Display unit, providing one line of 5 1/2 digits. The screen shows the weights read from the pad. The TOTAL icon indicates measurement mode as in the table below the LP600 display. Information displayed includes indicators for both “lb” and “kg”, a segment bar to show battery charge level, error conditions and set-point indicators when set-point thresholds are reached. The display contains an automatic backlight for use in low-light conditions.

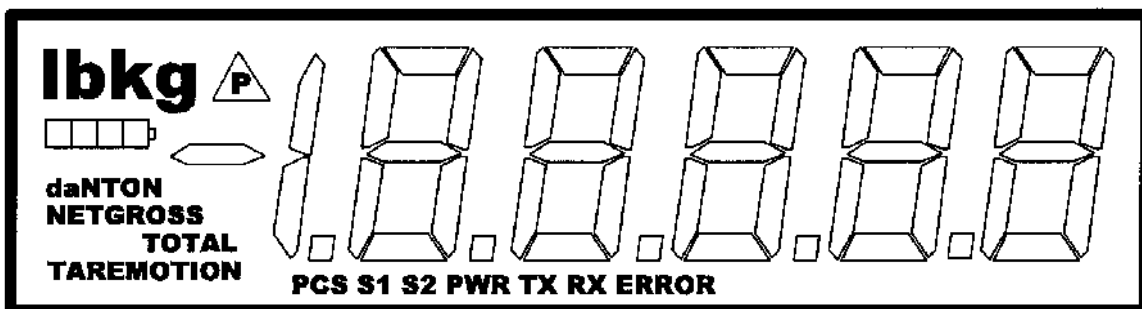

Mode status	Setting
TOTAL not lit	Local
TOTAL lit	Total
TOTAL flashing	Accumulated Total

Controls



ON / OFF

Press and hold this key to apply power to the weighing system electronics. Make sure to hold this key until the display responds (up to 1 second). When power is first applied, the weighing system rapidly performs self-tests of the pad and the internal electronics. When the tests have completed successfully, the system begins weighing. If a problem is detected, the screen displays an error message.

If the LP600 is powered up, press this button to turn the scale off. The LP600 retains the setup information, and calibration in a special memory device (non-volatile memory) that is not affected by power loss or battery condition.

PRINT / ACCUMULATE

This control will be rarely used with a LP600 system. This function is used in cabled scales with no central CPU or indicator.

Press this button to print. When using the accumulated total function: press the PRINT / ACCUMULATE button to add the total to the accumulated total. See section titled "Using Accumulated Total".

New accumulated total = total weight (all scales in system) + old accumulated total

Once a successful accumulation has occurred, the scale will automatically toggle its display to show the current weight, accumulated total, and number of accumulations.

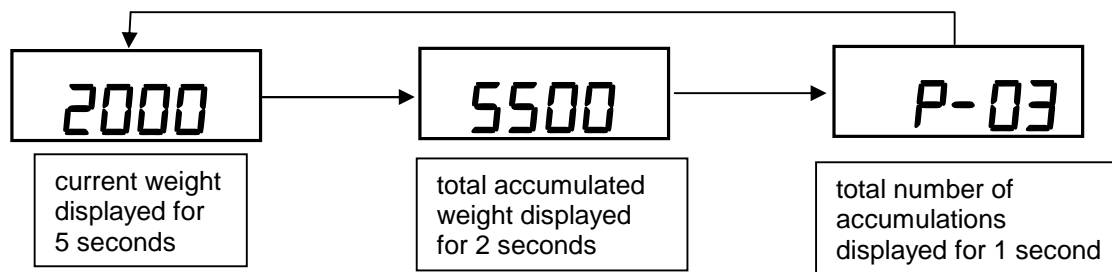

Note: The scale will not accumulate and will display the error message “*Ac.Err*” if the current weight is negative, zero, or if the weight is in motion. These Protections are added to ensure that only valid readings are accumulated into the total. Also, after a successful accumulation, ALL scales in the system must return to zero before you accumulate the next weight. If you attempt to accumulate the next weight before allowing the scale(s) to return to zero, the error message “*Ac.Err*” will be displayed.

The accumulated total weight can be viewed only on the scale you are accumulating from. After the PRINT/ACCUMULATE button is first pushed; the display will show “*Ac. X*” as the system will accumulate the next reading and send it to print. (X will show the number of accumulations this session) Once a successful accumulation has occurred, pressing the LOCAL/TOTAL button will cycle the display to show number of accumulations, current local weight, current total weight on all scales, and the accumulated total. When the local weight, current total weight, or accumulated total is displayed, the total icon will be lit up, flashing, or off. (as shown in the display description).

LOCAL / TOTAL

This control will be rarely used with a LP600 system. This function is used in cabled scales with no central CPU or indicator.

The local weight is the weight on that scale only. The total weight is the weight on all of the scales in your system. Pressing the LOCAL / TOTAL button toggles between local weight and total weight. The Mode status (as shown in the display description) will show whether the scale is displaying the local or total weight.

Note: If the system is not setup correctly, the “error” icon and message “*Err*” will be displayed when trying to view the total weight. See section titled “Totalizing Setup”.

ZERO

Sets the weighing system to read zero pounds or kilograms. If pressed while a pad holds weight, that weight becomes the zero condition for the pad. This can be useful to cancel the weight of any weighing fixtures, such as tail cones or wheel chocks. When the weight is removed, a negative weight displays until the

system is re-zeroed. This switch is used any time the scale shows a non-zero value with no weight on the pads.

Note: This system contains a feature called Auto Zero Tracking (AZT), which corrects for slight zero changes during normal operation. An example of a zero change could be a buildup of dirt on the pads.

Another function of the zero key is to clear the accumulated total. Press and hold the ZERO key until the display reads “[Lr.t” and release the ZERO key. This will reset the accumulated total and the accumulation number. All other scales you have connected will also be zeroed through the interconnect cables. This allows you to zero your entire system with one key press.

Totalizing Setup

This section covers configuring a scale set for either self-totalizing or connection to a PC/PDA for advanced display features. For accumulating multiple weights on a scale or scale set, see the "Using Accumulated Total" section. In 'self-totalizing' mode, the LOCAL/TOTAL button works to switch between weight on that particular scale (LOCAL) and the total weight of connected scales (TOTAL). If the system is not setup correctly, the "error icon" and message "Err" will be displayed when trying to view the total weight.

1. To enter into totalizing setup: Simultaneously press the LOCAL/TOTAL and ZERO buttons.
2. Message "5L d" will be displayed. Press PRINT/ACCUMULATE button. A number will be displayed with 3 dashes following it. This is the scale number. Use the LOCAL/TOTAL button to increment and the ZERO button decrement the number. When the desired number is displayed, press the PRINT/ACCUMULATE.

scale #

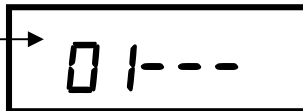

3. Message "5LL5" will be displayed. Press the PRINT/ACCUMULATE button. The display will show three dashes and then a number. This number is the total number of scales in the system. Use the LOCAL/TOTAL button to increment and the ZERO button decrement the number. When the desired number is displayed, press the PRINT/ACCUMULATE button. The maximum number of scales is 32.

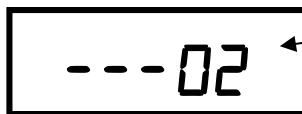

total # of scales
(only displayed on scale #1)

4. If the scale# is '1', the display will ask if the scale is the "HOST". Press the PRINT/ACCUMULATE button. Use the LOCAL/TOTAL or the ZERO button to toggle the display "YES" or "no". A 'Host' controls the scale network, and this setting should be set to "yes" if the scale network consists of scales only. If your system uses an external device such as a PDA or PC to view the weights, this setting should be set to "no" since the external host controls the network. Press the PRINT/ACCUMULATE button to save the setting.

Example 1 of correct scale settings: 4 pad system with PDA or PC:

	<u>Scale ID</u>	<u>Number of Scales</u>	<u>*Host setting</u>
Scale #1:	[01---]	[---04]	[no]
Scale #2:	[02---]	[---04]	
Scale #3:	[03---]	[---04]	
Scale #4:	[04---]	[---04]	

Example 2 of correct settings: 4 pad totalizing system using scales only:

	<u>Scale ID</u>	<u>Number of Scales</u>	<u>*Host setting</u>
Scale #1:	[01---]	[---04]	[YES]
Scale #2:	[02---]	[---04]	
Scale #3:	[03---]	[---04]	
Scale #4:	[04---]	[---04]	

* Host setting is only available when scale ID is set to '01'

Serial Output Setup

This setup is not necessary with a typical LP600 system. There are three different serial output modes for the LP600, "on-demand", "continuous", and "accumulating print". The rest of this section provides more information on these modes.

To setup the serial output mode: Press the PRINT/ACCUMULATE and ZERO buttons simultaneously until the display shows "b.L tE". Press the PRINT/ACCUMULATE button to scroll through the menu (12 times) until the display shows "P-r t". Press the PRINT/ACCUMULATE button once to display setting number. Set print mode to the number of the print mode wanted by using the LOCAL/TOTAL button to increment and the ZERO button decrement the number. .

Communication Mode	Setting
On-Demand	0
Continuous	1
Accumulating Print Axle	2
Accumulating Print Standard	3

Note: For best results, only set **one** scale to '1', '2' or '3'. This should also be the scale you are printing from. '0' is the default setting.

Press the PRINT/ACCUMULATE button. Now the display will display "PbAUd". Press the PRINT/ACCUMULATE button to change the baud rate set, press the LOCAL/TOTAL or the ZERO button to cycle through the baud rates available. The baud rates available are: 1200, 2400, 4800, 9600, 19200, 38400, 57600, and 115200. When the desired baud rate is displayed, press the PRINT/ACCUMULATE button. The baud rate only needs to be set on the scale doing the printing. The settings are saved once PRINT/ACCUMULATE is pressed to advance the menu, and the scale can then be turned off to exit the Mode Menu.

On-Demand

The weight is transmitted every time the PRINT/ACCUMULATE key is pressed. Press PRINT/ACCUMULATE to print either the local or total weight (depending on the local/total setting of the scale). This is the default print mode.

Continuous

The LP600 automatically and continuously outputs the weight at a rate of about once per second.

Data Format

When the serial output is set to either on-demand or continuous mode, the transmitted data is in the format shown below:

AAAAAAA BB<cr><lf>

Item	Meaning	ASCII Hex	ASCII Decimal
AAAAAAA	weight		
BB	units "lb" or "kg"		
<cr>	carriage return	0D	13
<lf>	linefeed	0A	10

The AAAAAAA field will vary in length depending on the length of the number and could contain a decimal point and/or a minus sign. The weight will either be local weight or total weight, depending on which mode you're in.

Accumulating Print

See section titled "Using Accumulated Total" for both the Axle and the standard formats.

Weighing procedures

The LP600 platforms can be used separately, in pairs, or in groups of 4, 6, or more to measure a support load, wheel load, axle load, axle group load, or the total weight of a multi-axle truck in one measuring procedure.

Ideally, all wheels of a vehicle should be measured at the same time in order to avoid measuring errors due to the suspension system.

If you are not able to weigh the wheels of a tandem or triple axle simultaneously, the difference in height must be compensated for by using dummy plates (grids, wood or rubber plates) of the same height. The wheel load scales are put in front of the wheels of a vehicle. The driver then drives on the scales/plates and stops within the active weighing area. To avoid improper weighing which might be caused by wheel or axle load displacements, the vehicle brakes should be released before reading the weight values.

NOTES:

1. It is recommended to weigh the wheels of one axle at the same time.
2. The dummy plates can be omitted if the scales are embedded in recesses in the road surface at the same levels as the road surface.

Using Accumulated Total

The LP600 platforms can be used separately, in pairs, or in groups to measure a support load or the total weight in one measuring procedure.

To use the Accumulated Total feature, the scales need to be numbered correctly and the scale you intend to print from or display the accumulated total must have its print mode set to one of two 'Accumulating Print' modes. See the "Totalizing Setup" and "Serial Output Setup" sections for details.

Accumulating Print Axle

Press the PRINT/ACCUMULATE button to add the current total weight to the accumulated total weight. At the same time, a print ticket will be generated (assuming you have a printer in the system). The print ticket format is in respect to a vehicle's individual wheels and axles or a standard weight accumulation mode.

For example wheel and axle, think of "WHL 1" as scale 1 and "AXL 1" as the total weight of scale 1 and scale 2. The following print ticket example is a 4 scale system:

PRINT / ACCUMULATE
button has been pressed

```

WHL 1:  7460  WHL 2:  7400
  AXL 1:  14860
WHL 3: 10110  WHL 4: 10070
  AXL 2:  20180
SUBTOTAL GRP 1: 35040
ACCUM TOTAL: 35040
    
```

PRINT / ACCUMULATE
button has been pressed

```

WHL 1: 10110  WHL 2: 10070
  AXL 1:  20180
WHL 3:  9800  WHL 4:  9500
  AXL 2:  19300
SUBTOTAL GRP 2: 39480
ACCUM TOTAL: 74520
    
```

Once a successful accumulation has occurred, press the LOCAL/TOTAL button to toggle the display through the current local weight, current total weight, accumulated total, and the number of accumulations that make up the total.

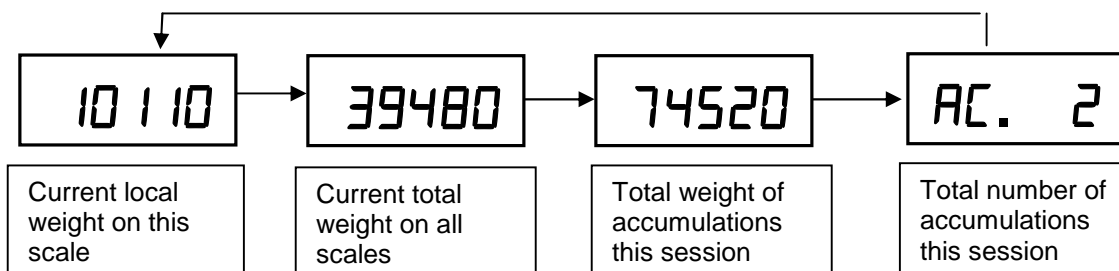

Note: The scale will not accumulate and will display the error message “**Acc.Err**” if the current weight is negative, zero, or if the weight is in motion. These Protections are added to ensure that only valid readings are accumulated into the total. Also, after a successful accumulation, ALL scales in the system must return to zero before you accumulate the next weight. If you attempt to accumulate the next weight before allowing the scale(s) to return to zero, the error message “**Acc.Err**” will be displayed.

The accumulated total weight can be viewed only on the scale you are accumulating from. After the PRINT/ACCUMULATE button is first pushed; the display will show “**Acc. X**” as the system will accumulate the next reading and send it to print. (X will show the number of accumulations this session) Once a successful accumulation has occurred, pressing the LOCAL/TOTAL button will cycle the display to show number of accumulations, current local weight, current total weight on all scales, and the accumulated total. When the local weight, current total weight, or accumulated total is displayed, the total icon will be lit up, flashing, or off. (as shown on page)

Accumulating Print Standard

A standard accumulation shows total weight of multiple items weighed on 1 or more scales. The following print ticket example is a 1 scale system after 3 items are weighed: (950lb, 1000lb, and 1500lb)

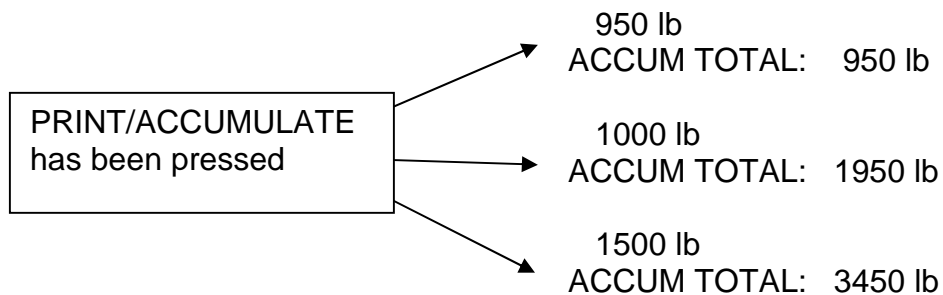

Once a successful accumulation has occurred, press the LOCAL/TOTAL button to toggle the display through the current local weight, current total weight, accumulated total, and the number of accumulations that make up the total.

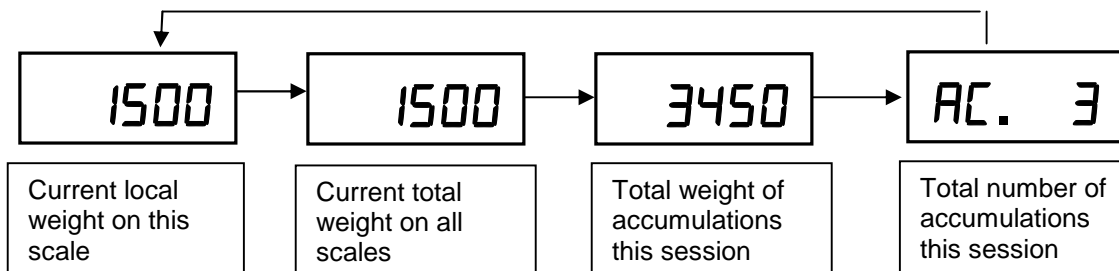

Note: The scale will not accumulate and will display the error message “**Acc.Err**” if the current weight is negative, zero, or if the weight is in motion. These Protections are added to ensure that only valid readings are accumulated into the total. Also, after a successful accumulation, ALL scales in the system must return to zero before you accumulate the next weight. If you attempt to accumulate the next weight before allowing the scale(s) to return to zero, the error message “**Acc.Err**” will be displayed.

The accumulated total weight can be viewed only on the scale you are accumulating from. After the PRINT/ACCUMULATE button is first pushed; the display will show “**Acc. X**” as the system will accumulate the next reading and send it to print. (X will show the number of accumulations this session) Once a successful accumulation has occurred, pressing the LOCAL/TOTAL button will cycle the display to show number of accumulations, current local weight, current total weight on all scales, and the accumulated total. When the local weight, current total weight, or accumulated total is displayed, the total icon will be lit up, flashing, or off. (as shown in the display description).

Note: In print-mode 3 it can accumulate either in local or total weight, but not when viewing the accumulated total.

To clear the accumulated total weight, press and hold the ZERO button until the display shows “**Err**”.

Accumulating Procedure:

1. With your system setup correctly, decide which scale you will accumulate from. This can be any scale, but once you choose, you must only accumulate with that scale until the weighing is complete. This scale needs to be set to your desired accumulate mode, 2 or 3 (See “Serial Output Setup”). If you are using a printer, select the scale directly connected to the printer.
2. With the first group of items stable on the scales, press the PRINT/ACCUMULATE button. If you are using a printer, a print ticket with all weights will now be printed. The display will return to the setting that the accumulation was taken from. This first group’s weight will become the accumulated total, which can be seen on the display by pressing the LOCAL/TOTAL button as described in the previous section with the TOTAL icon flashing. Another accumulation can not be made in the standard mode if the scale is in the Accumulation Print mode. (TOTAL icon flashing). After accumulation, remove the first group of items from the scale(s).
3. With the next group of items stable on the scale(s), press the PRINT/ACCUMULATE button. This will add the total weight to the accumulated total. If you are using a printer, a print ticket with all weights will now be printed.
4. Repeat step 3 as needed. If the accumulated total becomes too large to display, the “**d, SP**” message and error icon will be displayed.

5. When finished, you may clear the accumulated total weight by pressing and holding the ZERO button until the display show “**CLT**”. The display will clear the accumulated total and the number of accumulations.

Note: The scale will not accumulate when the weight is negative, zero, or if the weight is in motion. A display message “**AcErr**” with error icon will be displayed if any of those conditions are present. After a successful accumulation the scale must return to zero before you accumulate the next weight. If you attempt to accumulate the next weight before allowing the scale to return to zero, a display message “**AcErr**” with error icon will be displayed.

Mode Menu

Mode Menu

To access the mode menu simultaneously press the PRINT/ACCUMULATE and ZERO buttons. The display will show “*b.L tE*”. If it doesn’t, go to Calibration Enable Jumper section and verify the scale is in the RUN position. (shorting pins 2 and 3(RUN))

At times it will be necessary to enter up to a five digit number. When this is necessary the current number will be displayed with the right most digit flashing. The flashing digit may be incremented by pressing the LOCAL/TOTAL button. To move one digit to the left, press the ZERO key. When you have finished entering a number press the PRINT/ACCUMULATE button. The settings are saved once PRINT/ACCUMULATE is pressed to advance the menu, and the scale can then be turned off.

Step	Function	Note	Default
<i>b.L tE</i>	Backlight	<i>AUt o, on, oFF</i>	<i>AUt o</i>
<i>SEtP 1</i>	Set Point 1	0 to 199999	<i>199999</i>
<i>SEtP 2</i>	Set Point 2	0 to 199999	<i>199999</i>
<i>vEr.</i>	Firmware Version	View only	XXXXXX
<i>A. r t</i>	Average rate	1 to 120	<i>008</i>
<i>A.tHrS</i>	Average threshold	1 to 10000	<i>200</i>
<i>A oFF</i>	Auto off	000 = off, 1 to 240	<i>060</i>
<i>Pr t t</i>	Print Mode	0 = On-demand, 1 = Continuous, 2 = Accumulating Total Axle, 3 = Accumulating Total Standard	<i>0</i>
<i>PbAUd</i>	Printer baud rate	1200, 2400, 4800, 9600, 19200, or 38400, 57600, 115200	<i>9600</i>
<i>Un tS</i>	Measurement units	lb or kg	lb
<i>Proto</i>	Protocol	<i>StAnd, Lo Pr, C.LOOP, or nonE</i>	<i>Lo Pr</i>
<i>.bAUd</i>	Interface baud rate	9600 or 115200	<i>9600</i>
<i>rAd io</i>	Radio Enable	Yes or no	<i>YES</i>
<i>rF CH</i>	Radio Channel	01 to 12	<i>1</i>
<i>rF.PAn</i>	Radio Network ID	0 to 65534	<i>8000</i>
<i>rF.ECP</i>	Radio Encryption Key	1 to 65534	<i>08000</i>
<i>rF.dEF</i>	Restore Radio Defaults	0 or 3	<i>0</i>

Setting the Mode Menu Parameters

1. Simultaneously press the PRINT/ACCUMULATE and ZERO buttons. The display will show “b.L tE”. Press the PRINT/ACCUMULATE button. The flashing display shows the current setting. Press the ZERO or the LOCAL/TOTAL buttons to toggle between Auto, on, and off. With ‘Auto’ selected (default), the backlight will automatically light up when low level light conditions are detected. When the desired setting is displayed, press the PRINT/ ACCUMULATE button.
2. The display will show “SEtP 1”. Press the PRINT/ACCUMULATE button. The flashing digit shows the current setting. When the weight displayed is equal to or greater than the set point, the corresponding icon is displayed on the LCD. During normal weighing mode, the S1 icon on the display will light when the weight is greater than or equal to set point 1. Use the LOCAL/TOTAL button to advance the number and the ZERO button to move the number flashing to the left. When the display shows the desired number, press the PRINT/ACCUMULATE button.
3. The display will show “SEtP2”. Press the PRINT/ACCUMULATE button. The flashing digit shows the current setting. During normal weighing mode, the S2 icon on the display will light when the weight is greater than or equal to set point 2. Use the LOCAL/TOTAL button to advance the number and the ZERO button to move the number flashing to the left. When the display shows the desired number, press the PRINT/ACCUMULATE button.
4. The display will show “vEr”. Press the PRINT/ACCUMULATE button and the display will show the current version of firmware loaded in the scale. Press the PRINT/ACCUMULATE button.
5. The display will show “R. rE”. Press the PRINT/ACCUMULATE button. The flashing digit shows the current setting. This number is how many readings will be averaged together before the reading is sent to the display. Higher values will result in a more stable reading, but will take longer to settle to the final value. Note that the scale updates at 4Hz, so an Average Rate of ‘8’ equates to 2 seconds of averaging. Enter a ‘1’ to effectively disable averaging. Use the Lb/Kg button to advance the number and the ZERO button to move the number flashing to the left. When the display shows the desired number, press the PRINT / ACCUMULATE button.
6. The display will show “R.tHr5”. Press the PRINT / ACCUMULATE button. The flashing digit shows the current **Average Threshold** setting. This setting enables dynamic averaging, which can improve the settling time of a large Average Rate. If the scale senses a large weight change, it will temporarily suspend averaging, jump to the new weight, and resume averaging. Enter a value of 1-10000 to set the threshold (in display divisions) at which the dynamic averaging triggers. Enter ‘0’ to disable dynamic averaging. When disabled, the averaging will never be suspended. When the display shows the desired number, press the PRINT/ACCUMULATE button.

7. The display will show "R. OFF". Press the PRINT/ACCUMULATE button. The flashing digit shows the current setting. The number displayed is the minutes that the scale can remain idle before it automatically shuts down. Setting this number to "000" will disable the function, meaning the scale will never shut itself off. Use the LOCAL/TOTAL button to advance the number and the ZERO button to move the number flashing to the left. When the display shows the desired number, press the PRINT/ACCUMULATE button.
8. The display will show "Prnt". Press the PRINT/ACCUMULATE button. The flashing digit shows the current setting. The number enables the scales different print modes. (0 for on-demand, 1 for continuous, 2 for accumulating total axle format, and 3 for accumulating total standard format) Use the LOCAL/TOTAL button to increment and the ZERO button to decrement the number. When the display shows the desired number, press the PRINT/ACCUMULATE button.
9. The display will show "PbAud". Press the PRINT/ACCUMULATE button. The flashing display shows the current setting of the printer baud rate. The baud rates available are: 1200, 2400, 4800, 9600, 19200, 38400, 57600, and 115200. Use the LOCAL/TOTAL button or the ZERO button to toggle through the available rates. When the display shows the desired number, press the PRINT/ACCUMULATE button.
10. The display will show "Un t5". Press the PRINT/ACCUMULATE button. The lb or the kg icon will flash in the upper left of the display. This will set the scale to measure pounds (lb) or kilograms (kg). Use the LOCAL/TOTAL button or the ZERO button to toggle between the settings. When the desired icon is flashing, press the PRINT/ACCUMULATE button.
11. The display will show "Protol". Press the PRINT/ACCUMULATE button. The flashing display shows the current setting. There are 4 protocol settings for the scale, Standard ("StAnd"), Low Power ("Lo Pr"), Current Loop ("CLoop"), or "none". Standard is the legacy setting for use in wireless and wired scale networks. Low Power will significantly improve the wireless battery life for all non-'host' scales. (maximum number of scales in this mode is 32) Current Loop is not used in the LP600. When scales are not part of a totalizing network, battery life will be improved if "none" is chosen. Use the LOCAL/TOTAL button or the ZERO button to cycle through the settings. When the desired protocol is flashing, press the PRINT/ACCUMULATE button.
12. The display will show "i.bAud". Press the PRINT/ACCUMULATE button. The display will show the current setting flashing. This is the setting of the interface baud rate. There are two settings available, 9600 and 115200. Use the LOCAL/TOTAL button or the ZERO button to toggle between the settings. When the desired baud rate is flashing, press the PRINT/ACCUMULATE button.

13. The display will show “rAd id”. Press the PRINT/ACCUMULATE button. The display will show the current setting flashing. This is the radio enable status and is either on or off. Use the LOCAL/TOTAL button or the ZERO button to toggle between the settings. When the desired status is flashing, press the PRINT/ACCUMULATE button. If you select “no” the scale will skip the rest of the settings and return to normal weighing.
14. The display will show “rF CH”. Press the PRINT/ACCUMULATE button. The flashing digit shows the current setting. All scales in a system must be set to the same radio channel setting in order to communicate with each other. Use the LOCAL/TOTAL button to increment and the ZERO button to move the number flashing to the left. When the display shows the desired number, press the PRINT/ACCUMULATE button.
15. The display will show “rF.PAn”. Press the PRINT/ACCUMULATE button. The display will show the current setting with the number on the right flashing. All scales in a system must be set to the same Personal Area Network ID setting in order to communicate with each other. Use the LOCAL/TOTAL button to increment and the ZERO button to move the number flashing to the left. When the display shows the desired number, press the PRINT/ACCUMULATE button.
16. The display will show “rF_ECP”. Press the PRINT/ACCUMULATE button. The display will show “00000” with the number on the right flashing. Use the LOCAL/TOTAL button to increment and the ZERO button to move the number flashing to the left. Enter any number from 1 to 65534 to enter an encryption key, or enter 0 to leave the current encryption key unchanged. For security purposes, this setting is not accessible to view and will always show as “00000”. All scales in a system must be set to the same encryption key setting in order to communicate with each other. When the desired encryption key is displayed, press the PRINT/ACCUMULATE button.
17. The display will show “rF.dEF”. Press the PRINT/ACCUMULATE button. The display will show “0” with the number flashing. Use the LOCAL/TOTAL button to increment and the ZERO button to decrement the number. Setting the number to 3 will restore the default radio settings. All other numbers will have no affect on the radio set-up. When the desired number is flashing, press the PRINT/ACCUMULATE button. The scale will return to normal weighing.

If the scale does not have the radio option installed, the “rF CH”, “rF PAn”, “rF ECP” and the Encryption key will be view only.

Calibration

Notice: The LP600 scale is calibrated by the factory prior to shipment.

Note: If the LP600 scale is calibrated using dead weights the correct altitude and latitude must be set. If it is calibrated using a force calibration press the altitude must be set to 0 feet and the latitude set to 45 degrees.

Note: The calibration will achieve the best accuracy if calibration loads are applied to LP600 platform through a metal block, separated from the platform by a thick piece of firm rubber; this setup best simulates the load applied by a tire. Loading without a block can damage the scale. See Tool List below for complete specifications.

Procedure: Calibration (Verification)

Tools required:

- Calibration force generator; press or deadweights. This calibration source must cover the range of 10% to 100% of nominal capacity with an accuracy of 0.025% of reading or better.
 - 100267 - 10" (± 0.25 ") x 17" (± 0.25 ") x 1.75" (minimum) aluminum loading block.
 - 100268-A - 10" (± 0.25 ") x 17" (± 0.25 ") x 0.5" (± 0.125 ") rubber loading scale. (40 to 70 Shore A rating)
1. Bring the scales to the calibration site. If there is more than 5°F difference in temperature between the scale temperature and the calibration site allow the scales to reach room temperature.
 2. Place scale on calibration fixture.
 3. Using the following table, apply the specified test forces:

20K Capacity		
Test force (lb)	Lower limit (lb)	Upper Limit (lb)
0	0	0
2000	1980	2020
4000	3960	4040
6000	5940	6060
8000	7920	8080
10000	9900	10100
12000	11880	12120
14000	13860	14140
16000	15840	16160
18000	17820	18180
20000	19800	20200
0	-20	20

4. Verify that each display value is within the limits shown.

5. If any value is out of acceptable limits proceed to the adjust calibration procedure.
6. If all values are within acceptable limits continue with corner verification.

The corner calibration is set at the factory at time of shipment. It may be necessary to make adjustments to the corner settings after replacing a load cell. Corners must be checked if the unit fails the calibration verification check. This section is intended as information to someone already familiar with the concepts of load cell summing.

There are six load cells within the LP600 scale; they are numbered as in Figure 1.

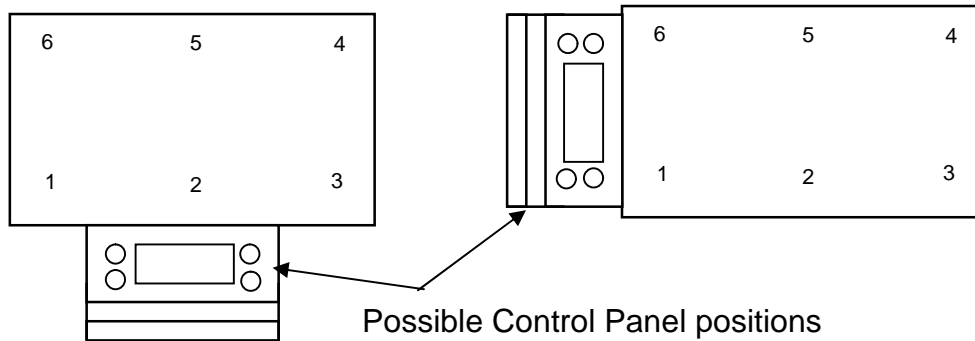

Figure 1

Tools required:

- 3000 pound calibration press.
- 111115 – 3” Calibration Puck
- 100319 – LP 6 cell corner fixture.
- 100259-A - 15" (± 0.25 ") x 22" (± 0.25 ") x 0.5" (± 0.125 ") rubber loading scale. (40 to 70 Shore A rating)
- 140208 - #2 Phillips screwdriver.
- 140210 - Static dissipation station.

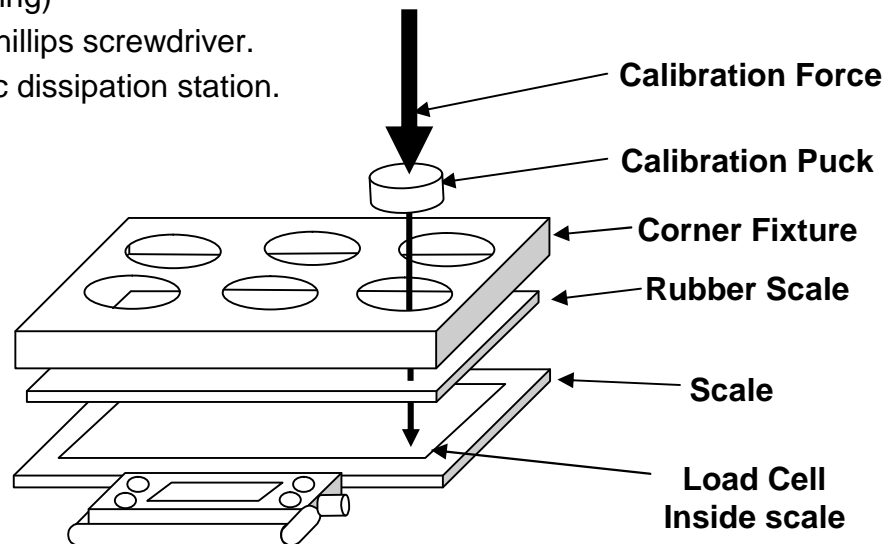

Figure 2

Assembly and use of corner alignment fixture

7. Position the corner fixture with rubber pad on the scale as per figure 2. Apply $\frac{1}{4}$ of the scale's capacity to the loading block. Annotate the reading.
8. Repeat for the other five positions.
9. If all readings are within 5 pounds and the previous calibration passed, the calibration verification is complete. If multiple corner checks fail go to the Multiple Corner adjustment. If a single corner fails go to Single Corner adjustment.

This concludes the verify calibration procedure.

Procedure: Calibration (Adjustment)

Tools required:

- Calibration force generator; press or deadweights. This calibration source must cover the range of 10% to 100% of nominal scale capacity with a certified accuracy of 0.025% of reading or better.
- 100267 - 10" (± 0.25 ") x 17" (± 0.25 ") x 1.75" (minimum) aluminum loading block.
- 100268-A - 10" (± 0.25 ") x 17" (± 0.25 ") x 0.5" (± 0.125 ") rubber loading scale. (40 to 70 Shore A rating)
- 140208 - #2 Phillips screwdriver.
- 140210 - Static dissipation station.

Calibration Enable Jumper

To access the calibration mode the shorting strap labeled "RUN/CAL", located on the right-middle of the circuit board (Intercomp, A/D 20 BIT rev E), it must be moved from shorting pins 2 and 3(RUN); to shorting pins 1 and 2(CAL). To access the shorting strap, remove the 10 screws on the outside edges of the display assembly. Carefully lift the display assembly up and place the assembly, display side down, on top of the weighing platform.

Note: Care must be taken to ensure the wire harness is seated properly to prevent it from being pinched between the display assembly and the scale casing.

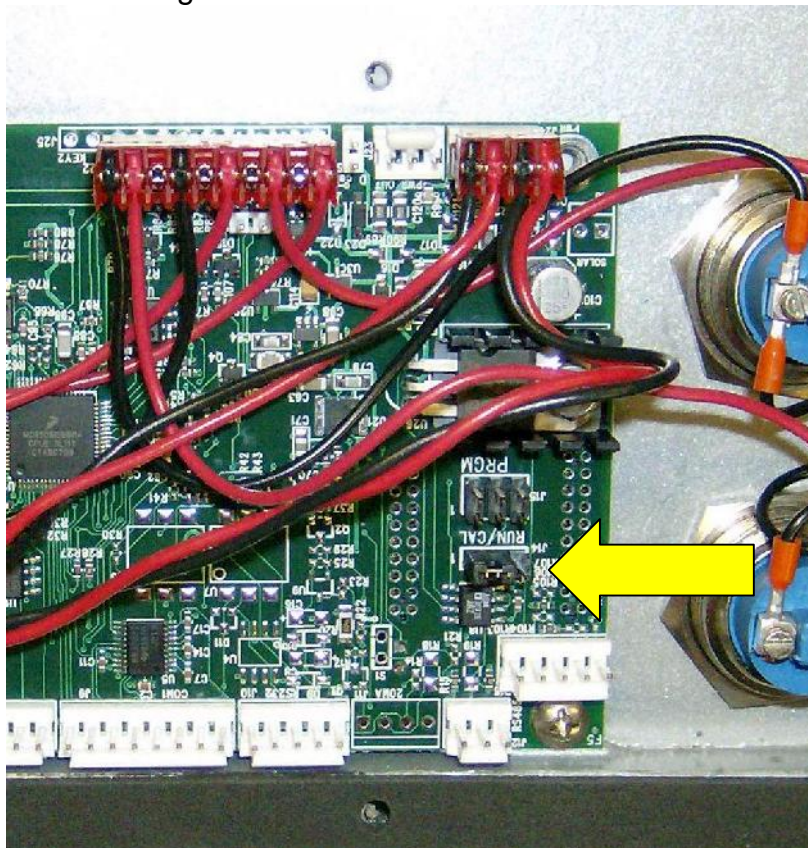

Following calibration, replace the strap to shorting pins 2 and 3 (RUN); replace the assembly and reattach the assembly with the screws. This will ensure that the calibration information of the scale is protected from being changed.

Note: Care must be taken to ensure the wire harness is seated properly to prevent it from pinching between the display assembly and scale casing.

Multiple Corner Adjustment

The corner calibration is set at the factory at time of shipment. It may be necessary to make adjustments to the corner settings after replacing a load cell or the control printed circuit board. Corners must be checked if the unit fails the calibration verification check.

There are six load cells within the LP600 scale; they are numbered as in Figure 1.

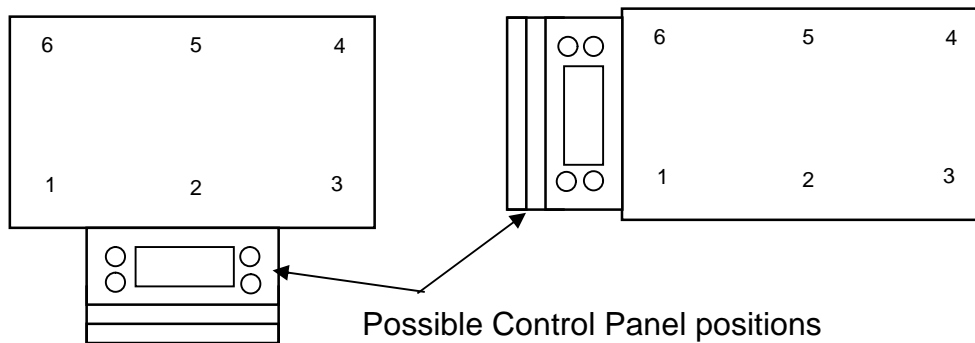

Figure 1

Tools required:

- 3000 pound calibration press.
- 100259-A - 15" (± 0.25 ") x 22" (± 0.25 ") x 0.5" (± 0.125 ") rubber loading scale. (40 to 70 Shore A rating)
- 111115 – 3" Calibration Puck
- 100319 – LP 6 cell corner fixture.
- 140208 - #2 Phillips screwdriver.
- 140210 - Static dissipation station.

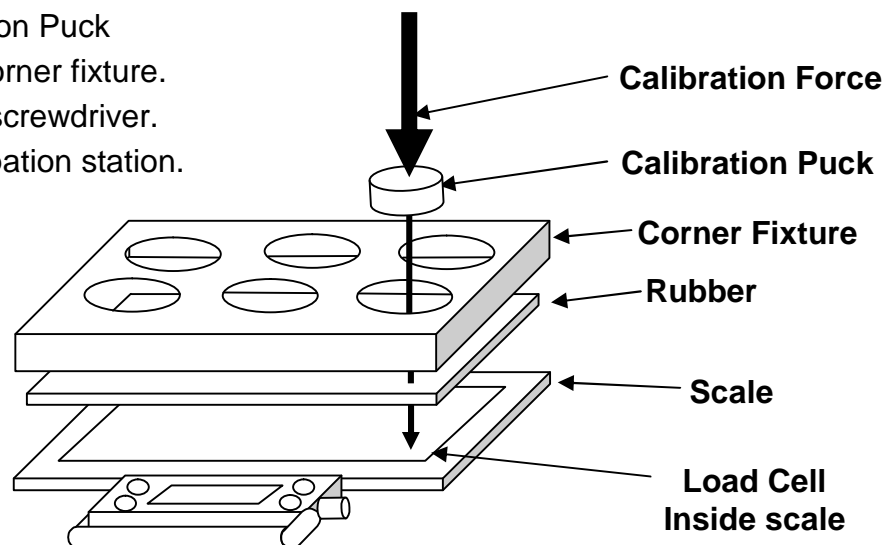

Figure 2
Assembly and use of corner alignment

Caution: Avoid directly touching any exposed circuitry. Use cotton gloves or similar protection. Oils from the fingers will cause unacceptable performance in high humidity conditions. This degradation may not be obvious at the time of contamination. If the circuitry becomes contaminated it must be cleaned using isopropanol or an equivalent cleaner.

Caution: The following procedure must be performed at a static controlled workstation. The main printed circuit board is subject to damage by electrostatic discharge.

1. Turn scale ON.
2. Press the PRINT / ACCUMULATE button. The display should show "SEEP". If not return to the Cal Enable Switch Access section and press the cal enable switch. Press the PRINT / ACCUMULATE button.
3. The display shows "000" with the most right digit flashing. Increase the number with the Lb/Kg button until the display shows "003". This will access the **Load Cell Balance** routine. Press the PRINT / ACCUMULATE button.
4. The display shows "LC.bAL". Press the PRINT / ACCUMULATE button and the display will show one digit flashing. This is the number of load cells in the scale. Increase the number with the Lb/Kg button or decrease the number with the Zero button until the display shows "5". This is the number of load cells in the LP600. If the number was changed the scale will save and restart. If this happens go back to step 2. If the number isn't changed the display will show "LC 00".
5. Press PRINT / ACCUMULATE to read the zero load. For this step it doesn't matter if there are loading blocks on the scale or not.
6. The display will show "LC 1-0". Prepare load cell 1 using the loading block and the rubber pad as per figures 1 and 2 above. With no weight on the scale except the loading block fixture, press the PRINT / ACCUMULATE button.
7. The display will show "LC 1-L". Apply ¼ of the capacity of the scale to load cell 1 using the same loading fixture. Once the load is applied press the PRINT / ACCUMULATE button.
8. The display will show "LC2-0". Prepare load cell 2 using the loading block and the rubber pad as per figures 1 and 2 above. With no weight on the scale except the loading block fixture, press the PRINT / ACCUMULATE button.
9. The display will show "LC2-L". Apply ¼ of the capacity of the scale to load cell 2 using the same loading fixture. Once the load is applied press the PRINT / ACCUMULATE button.
10. The display will show "LC3-0". Prepare load cell 3 using the loading block and the rubber pad as per figures 1 and 2 above. With no weight on the scale except the loading block fixture, press the PRINT / ACCUMULATE button.
11. The display will show "LC3-L". Apply ¼ of the capacity of the scale to load cell 3 using the same loading fixture. Once the load is applied press the PRINT / ACCUMULATE button.
12. The display will show "LC4-0". Prepare load cell 4 using the loading block and the rubber pad as per figures 1 and 2 above. With no weight on the scale except the loading block fixture, press the PRINT / ACCUMULATE button.

13. The display will show "LC4-L". Apply $\frac{1}{4}$ of the capacity of the scale load cell 4 using the same loading fixture. Once the load is applied press the PRINT / ACCUMULATE button.
14. The display will show "LC5-0". Prepare load cell 3 using the loading block and the rubber pad as per figures 1 and 2 above. With no weight on the scale except the loading block fixture, press the PRINT / ACCUMULATE button.
15. The display will show "LC5-L". Apply $\frac{1}{4}$ of the capacity of the scale to load cell 3 using the same loading fixture. Once the load is applied press the PRINT / ACCUMULATE button.
16. The display will show "LC6-0". Prepare load cell 4 using the loading block and the rubber pad as per figures 1 and 2 above. With no weight on the scale except the loading block fixture, press the PRINT / ACCUMULATE button.
17. The display will show "LC6-L". Apply $\frac{1}{4}$ of the capacity of the scale to load cell 4 using the same loading fixture. Once the load is applied press the PRINT / ACCUMULATE button.
18. The display will show "SAFE" and then return to normal weighing mode. The cornering has now been internally compensated and saved. Perform corner calibration verification in normal weighing mode. This concludes the corner sensitivity adjustment procedure. Return to calibration verification section and ensure all calibration parameters are met.

Single Corner Adjustment

1. Position the scale, loading block and pad to apply weight on the corner requiring adjustment.
2. Enter Cal mode.
3. Enter "20x" at "STEP" choice to adjust a single corner. The cell number to adjust is entered in the code as 'x'. (Example: Enter "202" to enter mode to adjust cell #2).
4. The display will appear to return to normal mode, except that now the 'S1' and 'S2' segments are blinking to indicate you are now in corner adjust mode for your selected corner.
5. Apply $\frac{1}{4}$ of the scales capacity to the loading pad over the corner to be adjusted.
6. Press LOCAL/TOTAL to increase or ZERO to decrease the corner's weight. (Each press adjusts the display approximately 0.01%)
7. When the desired weight is showing on the display, press PRINT / ACCUMULATE to save the results and return to normal weighing. Return to calibration verification section and ensure all calibration parameters are met.

Calibration menu

To initiate calibration simultaneously press the PRINT/ACCUMULATE and ZERO buttons. The display will show “*SkEP*”, if it does not, the calibration strap is incorrectly placed to allow calibration. Return to ‘Calibration Enable Jumper’ section to verify correct setting. Press the PRINT/ACCUMULATE button to access the parameter setting.

At times it will be necessary to enter up to a five digit number. When this is necessary the current number will be displayed with the right most digit flashing. The flashing digit may be incremented by pressing the LOCAL/TOTAL button. To move one digit to the left, press the ZERO key. When you have finished entering a number press the PRINT/ACCUMULATE button. The settings are saved once PRINT/ACCUMULATE is pressed to advance the menu, and the scale can then be turned off.

Step	Function	Note	Default
<i>SkEP</i>	skip	000= no skip See Calibration “Step” codes	<i>000</i>
<i>U. EnA</i>	Unit enable	Yes or no	<i>YES</i>
<i>bP 1</i>	grad break point 1	Enter weight	<i>00000</i>
<i>bP 2</i>	grad break point 2	Enter weight	<i>00000</i>
<i>bP 3</i>	grad break point 3	Enter weight	<i>00000</i>
<i>AdC.rte</i>	ADC rate	0 or 1	<i>1</i>
<i>AZt</i>	AZT (auto zero tracking)	1 d, 3 d, .5 d, oFF, or.6 d	<i>1 d</i>
<i>ZER0.r</i>	Zero range	0= off, 1= 1%, 2= 2%, 3= 5%, 4 = 1%	<i>0</i>
<i>GrAd</i>	graduation size	0.02, 0.05, 0.1, 0.2, 0.5, 1, 2, 5, 10, 20, 50, or 100	<i>d 1</i>
	<i>SALE</i>	Displays for 1 sec and advances	
<i>CAP</i>	capacity	Enter scale capacity	<i>20000</i>
<i>LL-00</i>	No weight applied		
<i>HH-01</i>	First weight	Enter first weight	
<i>LL-01</i>	First weight	Load first weight	
<i>HH-02</i>	Second weight	Enter second weight	
<i>LL-02</i>	Second weight	Load second weight	
<i>HH-03</i>	Third weight	Enter third weight	
<i>LL-03</i>	Third weight	Load third weight	
<i>HH-04</i>	Fourth weight	Enter fourth weight	
<i>LL-04</i>	Fourth weight	Load fourth weight	
	10 points available to enter	3 minimum recommended	

Setting the Calibration Parameters

1. At any point in the following steps, data will be retained by the scale at the step completed if the power is cycled off. To initiate calibration simultaneously press the PRINT/ACCUMULATE and the ZERO buttons. The scale shows “**STEP**”. Press the PRINT/ACCUMULATE button. The scale shows “**000**” with the far right number flashing. To go through all of the calibration parameters, press PRINT/ACCUMULATE with the display showing “**000**”. To skip the first 8 calibration parameters and proceed to step 10 enter “**00 1**”. See Diagnostics section for additional codes available. Use the LOCAL/TOTAL button to increment and the ZERO button to decrement the number. Press the PRINT/ ACCUMULATE button when the desired number is displayed.
3. The display shows “**U. ENR**” if proceeding through all parameters. Press the PRINT/ACCUMULATE button. The display will read “**YES**”. Pressing LOCAL/TOTAL or the ZERO button will toggle the display to “**no**”. With the display showing “**YES**”, press the PRINT/ACCUMULATE button.
4. The display now shows “**bP 1**”. Press the PRINT/ACCUMULATE button. The display will read the current setting with the far right number flashing. Use the LOCAL/TOTAL button to advance the number and the ZERO button to move the number flashing to the left. When the desired graduation break point is displayed press the PRINT/ ACCUMULATE button.
5. The display shows “**bP 2**”. Press the PRINT/ACCUMULATE button. Repeat the process in step 3 for graduation break point 2. When the desired graduation break point is displayed press the PRINT/ACCUMULATE button.
6. The display shows “**bP 3**”. Press the PRINT/ACCUMULATE button. Repeat the process in step 3 for graduation break point 3. When the desired graduation break point is displayed press the PRINT/ACCUMULATE button.

Multiple Graduation Break Points

The LP600 has the ability to have multiple graduation values set. Following is an example of setting graduation break points. Example:

Grad = Initial graduation equals by 0.1 lb
Cap = 10000 (Capacity equals 10,000 lb)
bP 1 = 1000
bP 2 = 2000
bP 3 = 5000

The scale would then display the following:

up to 1000 lb	by 0.1 lb;	up to 453.55 kg	by 0.05 kg
1000+ to 2000 lb	by 0.2 lb;	453.55+ to 907.1 kg	by 0.1 kg
2000+ to 5000 lb	by 0.5 lb;	907.1+ to 2267.8 kg	by 0.2 kg
5000+ lb	by 1.0 lb;	2267.8+ kg	by 0.5 kg

To disable the breakpoints the graduation break points should be set to 110% of the capacity. The scale uses the same graduation from zero to capacity. This turns off the breakpoint feature.

7. The display shows “**AdC.rE**”. Press the PRINT/ACCUMULATE button. The display shows the current setting flashing. This sets the internal A/D conversion time at one of two choices. An entry of ‘0’ results in the full conversion time for the most stable results. An entry of ‘1’ results in a reduced conversion time which extends battery life. For the LP600 it is recommended to leave this set to ‘1’. Note that if this setting is changed, the scale must be recalibrated. Use the LOCAL/TOTAL button to increment and the ZERO button to decrement the number. When the desired ADC rate is displayed press the PRINT/ACCUMULATE button.
8. The display shows “**AZE**”. Press the PRINT/ACCUMULATE button. The display shows the current setting. Press the LOCAL/TOTAL or the Zero button to cycle through the auto zero tracking options. (**1 d**, **3 d**, **.5 d**, **oFF**, or **5 d**) If the displayed weight is less than the number of grads shown for a given amount of time, the weight will be zeroed off. When the desired auto zero tracking setting is displayed press the PRINT/ACCUMULATE button.
9. The display shows “**ZE-D.r**”. Press the PRINT/ACCUMULATE button. The display shows the current setting flashing. Use the LOCAL/TOTAL button to increment and the ZERO button to decrement the number. The zero range is the percentage the zero can move from the original zero obtained at calibration. The zero button will not work if outside the zero range; and the display will show “**ZE-D.r**” with the error icon lit if the zero range is set to 1, 2, or 3. If 4-6 is selected, the zero button will simply not function when an attempt is made to zero the scale outside the range. When the number for desired zero range number is displayed press the PRINT/ACCUMULATE button. (0=off, 1=1%, 2=2%, and 3=5%, 4=1%, 5=2%, 6=5%)
10. The display shows “**GrAd**”. Press the PRINT/ACCUMULATE button. The display shows the current setting with the number flashing. Press the LOCAL/TOTAL or the Zero button to cycle through the graduation options. When the desired graduation setting is displayed press the PRINT/ACCUMULATE button. (grad options 0.02, 0.05, 0.1, 0.2, 0.5, 1, 2, 5, 10, 20, 50, or 100)

At this point the display will show “**SRUE**” for about 1 second and advance to show “**CAP**”.

Weight Calibration

One to ten load weights need to be applied to calibrate the scale. Using multiple point calibration allows the unit to weigh more accurately; by removing undesirable characteristics of load cells. A typical weight calibration is a three point calibration. This means three different and optimal loads are applied and entered (not including the zero point). If you do not conveniently have the three different weights available, you may also use one or two point calibration. To calibrate with one point, simply turn off the scale after completing step 13 as listed below. To calibrate with two points, turn off the scale after completing step 15 as listed below. The LP600 has the capability to apply and load up to 10 calibration points.

11. The display will show "SCALE" for about 1 second and advance to show "CAP". Press the PRINT/ ACCUMULATE button. The display will show the current capacity setting with the far right number flashing. Use the LOCAL/TOTAL button the advance the number and the ZERO button the move the number flashing to the left. Enter the capacity of the scale and press the PRINT/ACCUMULATE button when the scale capacity is displayed.
12. The display shows "LL-00". With no weight applied to the scale press the PRINT/ ACCUMULATE button.
13. The display shows "HH-0 1". Press the PRINT/ACCUMULATE button. The display will show "00000" with the far right number flashing. Use the LOCAL/TOTAL button to advance the number and the ZERO button to move the number flashing to the left. Enter the value of the first load and press the PRINT/ACCUMULATE button when the value of the first load is displayed.
14. The display shows "LL-0 1". Apply the first load to the scale. With the first load applied to the scale press PRINT/ACCUMULATE button.
15. The display shows "HH-02". Press the PRINT/ACCUMULATE button. The display will show "00000" with the far right number flashing. Use the LOCAL/TOTAL button to advance the number and the ZERO button to move the number flashing to the left. Enter the value of the second load and press the PRINT/ACCUMULATE button when the value of the second load is displayed.
16. The display shows "LL-02". Apply the second load to the scale. With the second load applied to the scale press PRINT/ACCUMULATE button.
17. The display shows "HH-03". Press the PRINT/ACCUMULATE button. The display will show "00000" with the far right number flashing. Use the LOCAL/TOTAL button to advance the number and the ZERO button to move the number flashing to the left. Enter the value of the third load and press the PRINT/ACCUMULATE button when the value of the third load is displayed.
18. The display shows "LL-03". Apply the third load to the scale. With the third load applied to the scale press PRINT/ACCUMULATE button.

19. The display shows "HH-04". Press the PRINT/ACCUMULATE button. The display will show "00000" with the far right number flashing. Use the LOCAL/TOTAL button to advance the number and the ZERO button to move the number flashing to the left. Enter the value of the forth load and press the PRINT/ACCUMULATE button when the value of the forth load is displayed.
20. The display shows "LL-04". Apply the forth load to the scale. With the forth load applied to the scale press PRINT/ACCUMULATE button.

Repeat step 12 and 13 for each additional "HH-05" – "HH 10" and "LL-05"- "HH 10" combination. If the scale is turned off at any time the calibration data acquired to that point will be retained. After the PRINT/ACCUMULATE button is pressed after "LL-10", the display will return to normal weighing.

Finished

Following calibration, replace the strap to shorting pins 2 and 3 (RUN); replace the assembly and reattach the assembly with the screws. This will ensure that the calibration information of the scale is protected from being changed.

Note: Care must be taken to ensure the wire harness is seated properly to prevent it from being pinched between the display assembly and the scale casing.

Troubleshooting

Problem Table

The following table describes some symptoms with possible causes and solutions.

Symptom	No power up, nothing on display
If any power reaches the control panel, the display driver turns on some random segments. Since we are not seeing this we will assume that no power is reaching the scale circuitry. Some possible causes: Defective wiring harness: Inspect for damaged wiring. Defective battery pack: Measure battery voltage, charge or repair as needed. Defective ON switch: Bridge switch to see if unit turns on. Defective circuitry: Replace control panel. The power supply may be delivering power, but it might be eaten up with a defective circuit board or cable. Unplug the load cell cable. If the scale turns on at this point, a load cell lead is shorted. Turn the power off and try each cell lead in turn. If it is the load cell cable, look for a crushed cable.	
Symptom	Power up to random display
We know that some power is reaching the display driver circuit, but the control panel is not working correctly. Test for low battery voltage. Inspect for visible damage. If this fails replace the control panel.	
Symptom	Scale shuts off
If the scale turns off IMMEDIATELY after you take your finger off the off button, you may have very low batteries. If this is not the cause replace the control panel.	
Symptom	"Locks up"
The scale may be mis-programmed. This can be corrected by restoring the correct control parameters. If the Average Rate setting is very high, an active load may not update the display quickly which may be interpreted as a lock up	
Symptom	No backlight
Cover the light sensor window. If the light does not turn on, replace the control panel. Please note that the light is not visible in bright sunlight.	
Symptom	Slow operation
This may be caused by a programmed change in the filter setting. There is a tradeoff between speed and stability of the display reading. This can be tuned by changing the "Average Rate" setting.	
Symptom	Low battery indicator won't turn off
It is possible that the output from the batteries is really low. Look at the cells and charger circuit for these problems. If the battery voltage is correct then you will need to replace the control panel.	
Symptom	Jumpy or drift weights
This can usually be traced to contamination on circuit boards or a bad load cell. This can also be caused by a rapid change in temperature. The scales need at least one-hour acclimation time for each 10 degrees Fahrenheit of temperature change. Another possibility is powerful radio interference.	
Symptom	No response to one or more keys
The switch may be defective. The control panel may be defective. The zero key does not function while the scale is in motion, this is not a defect. Also, the scale may be programmed to ignore the zero key if there is more than a certain amount of weight on the platform.	
Symptom	"Bad" weights
First, check weighing technique. Are there air currents around the vehicle being weighed? Are the operators using dummy blocks on the un-weighed wheels? (NOT a recommended technique) Are the scales being used on level ground? Is the scale set on the wrong units settings? Is a new operator using the scales? If on a calibration press, are you using weight distribution blocks and rubber scales? Is the reference scale correct? Assuming all this, is the scale spanned correctly? If the reading is exactly 3/4 of the expected value, one of the cells leads may not be providing signal. This would probably be in the load cell or control circuit. The interconnecting wiring or cables may be pinched, cut or crushed.	
Symptom	Batteries won't charge
Check for bad batteries. The charger circuit could be out. Check for bad connections or a defective charging cable. Look at the power source, whether it's a plug-in transformer, transport cart, or automotive ignition. Remove the battery cap with the scale plugged into the charger. If the scale turns on then the charger is working.	

Caution: Changing any circuit board or load cell will affect the calibration. The calibration should be checked after any repairs.

Error Messages

Error messages displayed can be a helpful diagnostic tool. The following table describes some possible causes and solutions.

Message	Meaning
'EEPE'	EEPROM FAILURE Calibration information lost or corrupted
Calibration information is held in a special permanent memory area. A checksum code is generated and written to this memory during the calibration process. Each time the power is turned on this code is regenerated and compared to the stored value. If a change is found this error message is displayed. Recalibration may clear the error display, but if the problem persists the control panel will have to be replaced.	
'Ad I'	A/D converter failure
The A/D circuit board has indicated a fault and needs to be repaired or replaced.	
'L[bxx]'	Power-up Self Test has detected one or multiple load cell errors
A load cell may have failed or there is a bad connection. The "xx" shows which cell or connection has failed: xx=1-8 (single digit) if there is a single load cell failure. A two-digit value for "xx" is a code to indicate multiple cells have failed or are disconnected	
'L[xx]'	Run-time checking has detected one or multiple load cell errors
A load cell circuit may have failed or there is a bad connection. The "xx" shows which cell or connection has failed: xx=1-8 (single digit) if there is a single load cell failure. A two-digit value for "xx" is a code to indicate multiple cells have failed or are disconnected	
'Lo.bAt'	Low battery voltage
This message indicates that the control panel has measured the battery voltage and found it to be too low. The most likely cause is that the batteries need to be charged. If the charge indicator fails to light up when the charger is plugged in, then the charger or cable may be defective. If the batteries have been charged for the recommended time and fail to run for the specified duration, then the batteries may need to be changed. If a new set of batteries fail to correct the situation, then the control panel may need to be replaced. Also check the battery holder and wiring.	
'CAP'	Overload or calibration information lost or bad load cell
The control panel has detected a weight reading that is larger than expected. This may be caused by the application of too much weight to the platform. If this display is seen when there is no weight on the platform, then the most likely causes are a defective load cell or defective control panel. To isolate the problem, measure the signal across pins two and three on the load cell connector on the control panel. This should be between zero and one millivolt. If found to be higher or lower, then the load cell system must be checked. See procedure elsewhere in this manual. If the signal is within this range then the calibration data may be lost. Attempt to recalibrate the scale. If this does not clear the problem, then replace the control panel.	
'ZE r 0.r'	Zero Range Error
Scale tried to zero off a load outside the range specified in the zero range setting. Remove any load and press zero.	
'd 1SP'	Number can't be displayed (such as -99999)
The most common cause of this error is pressing the zero key with a full load on the scale. When the load is removed, the full number with a minus sign will not fit on the display. Pressing the zero key again will clear this display.	
'COP' or 'CLOC'	Diagnostic power-up message
This won't affect normal operations and can typically be ignored.	
'Tot'	Totalizing setup error
See the "Totalizing Setup" section for setup details. Or press LOCAL/TOTAL to change to the standard LOCAL display if totalizing is not needed.	

Diagnostic tests and voltage measurements

Charger voltage

Ensure the scale is off during the entire test. Remove the batteries and connect a meter across the battery compartment observing correct polarity. Plug the battery charger in, the voltage should measure about 14.5V DC. Unplug the battery charger and reinstall the batteries. Measure the voltage across the batteries. Depending on the state of charge on the batteries the voltage should be between 4 to 5.8V DC. Plug the charger back in. The voltage across the batteries should increase. If the correct voltage response is not observed, unplug the battery charger. Remove one of the batteries and connect a meter, set to measure current to the battery compartment connectors, observing correct polarity. Plug the battery charger in. The meter should read between 25 and 75 mA DC.

Lamp

Cover the light sensor. The backlight should light up. Please note that it is difficult to see the backlight in sunlight.

Keys

Press **On/Off button**, the scale should turn on. Press **lb-kg**, the scale should change units of measure. Apply 50 lb to 250 lb to the scale. After you get a stable display, press the **ZERO** key. The scale should go to a zero indication. Press the **On/Off button** and the scale should turn off.

Power down shutoff

Connect a variable supply to the input connector and remove the batteries. Connect the meter to the positive battery lead. Set the supply to 6 V and turn the scale on. Reduce the input voltage until the scale turns off. The voltage at shutoff should be between 3.2 and 3.5 Volts.

Load Cells

Each LP600 scale has six load cells. These load cells are the transducers that convert mechanical energy (weight) to electrical energy.

Each load cell has 4 strain gages (700 Ω) and two temperature compensation thermistors. The four strain gages are wired together to form a Wheatstone bridge.

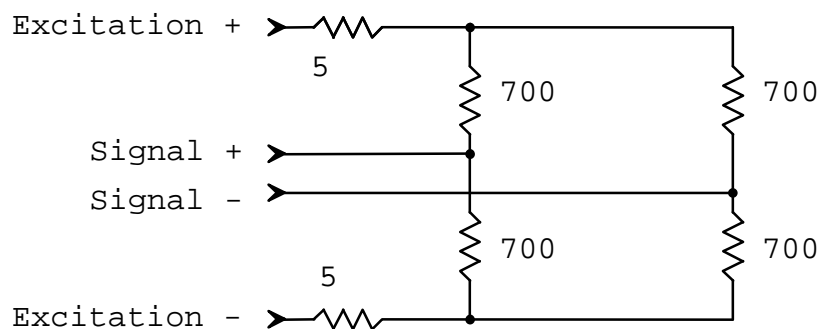

Schematic Diagram (typical values)

The 5 thermistors in series with the Excitation leads are for temperature compensation. They are balco thermistors that change resistance with temperature to maintain a constant signal voltage. These thermistors are specially manufactured for Intercomp load cell material and strain gage types.

Load cell leads color coding

Red : + Excitation (3.3 Volts)
Green : + Signal
White : - Signal
Black : - Excitation (ground)

Check load cell zero output value

The signal at the main circuit board with the signal leads in place should be approximately 0.1 millivolts with no load applied to the cell. Larger values could indicate a defective load cell, wiring, or circuit board. The load cell must be tested separately to determine the source of the zero shift.

Check zero output from the load cell

You can use a power supply set to 3.3 Volts to provide the excitation voltage for this measurement. Connect plus 3.3 volts to the red lead and ground to the black lead or use the scale to provide the excitation by connecting the two excitation leads only (Black and Red). Turn the scale on to apply excitation voltage.

Connect a meter capable of monitoring millivolt readings between the plus and minus signal leads (Green and White) The zero signal output (With excitation voltage applied) should measure approximately -1.00 to 1.00 millivolts). Larger values would indicate a defective load cell. This is most likely the result of an overload of the cell during use.

Check load cell resistance values

Load cell resistance can vary depending on the model and capacity. The load cells will be one of the standard resistance values given in the table below.

Nominal Cell Resistance		350 h	700 h	1000 h
Black – Red	=	385 Ω	770 Ω	1082 Ω
Black – Green	=	285 Ω	595 Ω	748 Ω
Black – White	=	285 Ω	595 Ω	748 Ω
White - Green	=	350 Ω	701 Ω	1000 Ω

With the load cells disconnected, the resistance readings should be as specified. It is normal for **all** of the readings to be higher or lower than the values given by several percent. If there is several Ohm **difference** between the Black-Green and Black-White measurements the cell is defective. This test is most useful to detect a catastrophic

failure of the cell or lead; you are typically looking for an open or a short when using this check.

Calibration “Step” codes

Cal Mode #	Enter Cal Mode # After “STEP” in Cal Menu
000	Advance through normal calibration menu.
001	Advance to weight calibration
003	Enter corner calibration. (Also set the number of load cell inputs here.)
005	Enter Mode menu. (the same menu that is entered if the cal strap is in the Run position)
101	Angle display diagnostic.
111	Individual cell read diagnostic. Next enter specific load cell number 1-8.
121	Raw Counts display diagnostic
131	Constant power to all load cells diagnostic
201-208	Corner adjust cell 1-8. (Example: 202 will enter mode to adjust cell #2).
311	Restore all radio settings to defaults (CH = 1, Network ID = 8000, Encryption = 8000. Display will then show ‘save’ if successful, or “no RF” if there is no radio installed or some other radio failure.
711	Default and save all settings (Leave calibration and cornering untouched)
811	Default and save corner compensation to nominal values
911	Default and save all board memory (settings, calibration, and corners)

Replaceable Parts

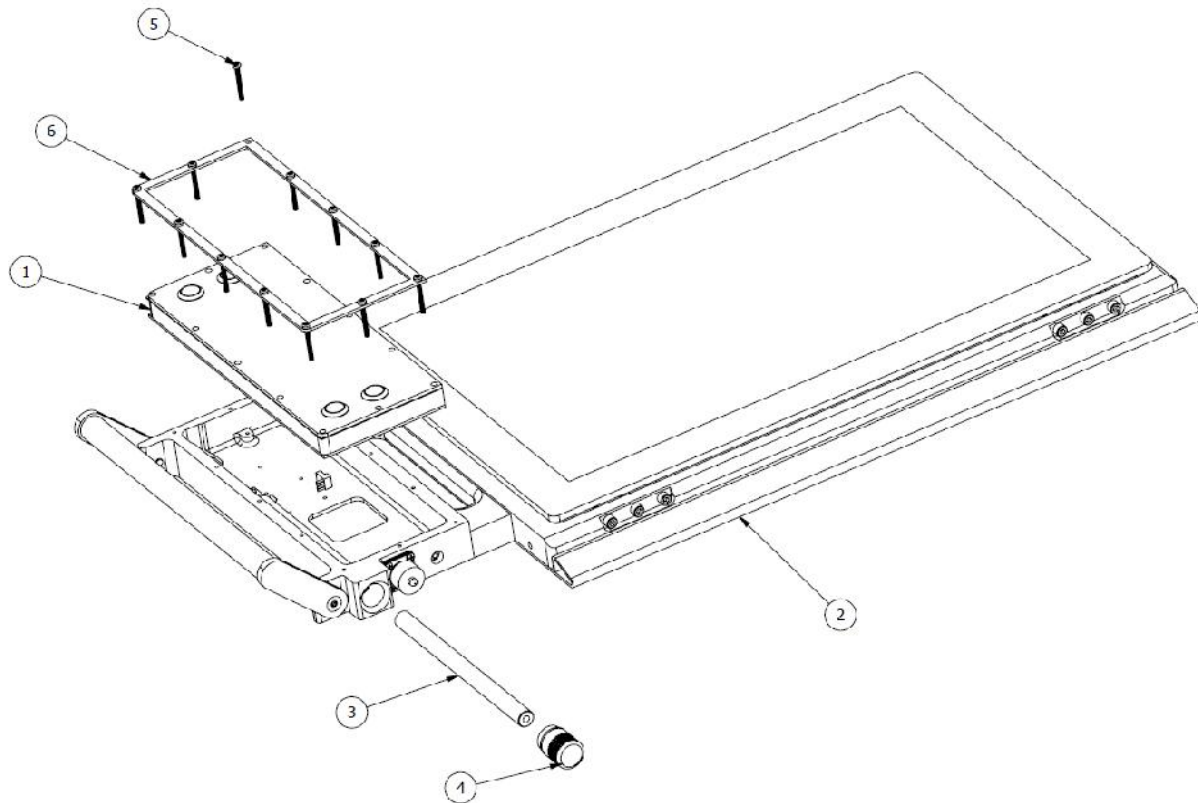

Index	Quantity	Part Number	Description
1	1	0200117	REV A LP600 SOLAR IND
2	1	506584	REV F LP 600 SCALE ASS 20K
3	1	330158	BATTERY STICK
4	1	000425	REV B BATTERY CAP ASS
5	12	600814	6-32UNC X 1.25 SS SCREW
6	1	5201438	REV A BEZEL FRAME

Connector

The diagram below shows the pin-out for the PT connector on the side of the LP600:

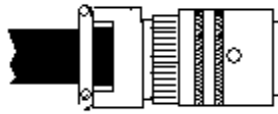

PT connector

- A:** RS-485 A
- B:** TXD (RS232)
- C:** - Charging Voltage
- D:** none
- E:** +Charging Voltage
- F:** Ground
- G:** RS485 B
- H:** none

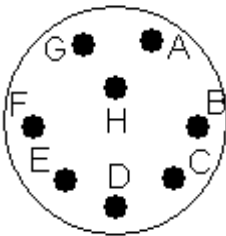

How to reach Intercomp

Things to know:

Inform the Service Dept. that the product is a LP600 scale.

When was the scale purchased?

Where was the scale purchased?

What is the serial number of the unit in for service?

For Intercomp Service call or fax:

or fill out Service Support Form at :

Copyright Intercomp Company© 2015

ALL RIGHTS RESERVED