

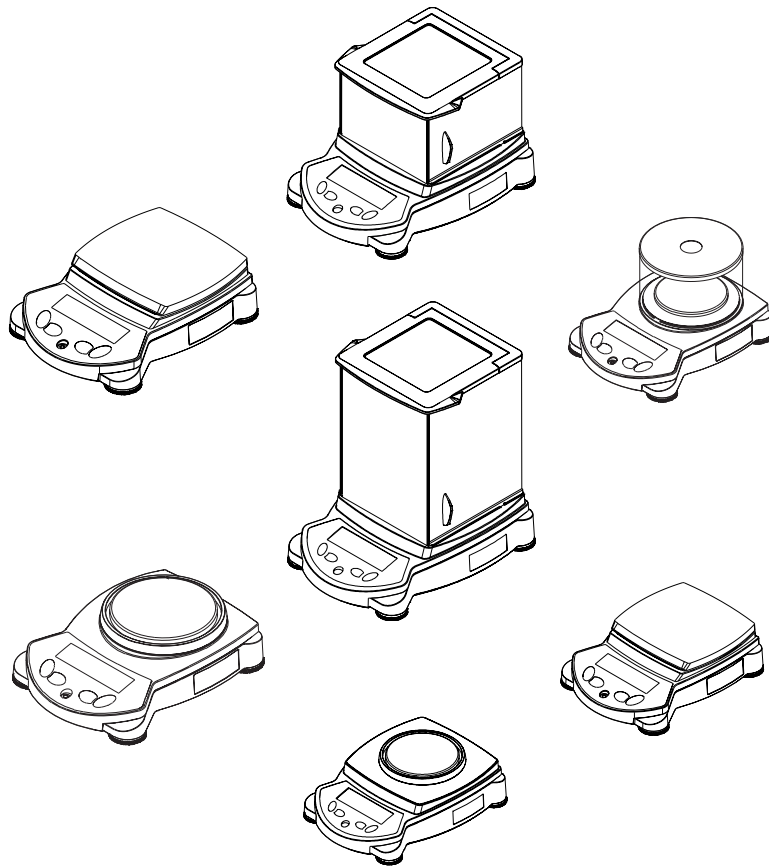

Adventurer Pro Balances Instruction Manual







Ohaus Corporation, 19A Chapin Road, P.O. Box 2033 Pine Brook, New Jersey, 07058, USA

Declaration of Conformity We, Ohaus Corporation, declare under our sole responsibility that the balance models listed below marked with "CE" - are in conformity with the directives and standards mentioned.

Instrument Type: Adventurer Pro AV Series

EC Marking:	EC Directive	Applicable Standards
CE	73/23/EEC Low Voltage	EN61010-1: 2001
	89/336/EEC Electromagnetic compatibility	EN61326-1:1997 +A1: 1998 +A2: 2001
<i>For non-automatic weighing instruments used in an Article 1, 2.(a) application, additional metrological marking according to Annex IV of Council directive 90/384/EEC must be attached to the instrument</i>		
CE ^{XX} 0103 M XX = Year	90/384/EEC Non-Automatic Weighing Instruments	EN45501:1992 *

* Applies only to certified non-automatic weighing instruments.



Date: January 1, 2005

Ted Xia
President
Ohaus Corporation
Pine Brook, NJ USA

Urs Müller
General Manager
Ohaus Europe
Greifensee, Switzerland



Compliance to the following standards is indicated by the corresponding marking on the product.

Mark	Standard
 N13123	AS/NZS4251.1 Emission; AS/NZS4252.1 Immunity
 55000	CAN/CSA-C22.2 No. 1010.1-92; UL Std. No. 3101-1

Note: This equipment has been tested and found to comply with the limits for a Class A digital device, pursuant to Part 15 of the FCC Rules. These limits are designed to provide reasonable protection against harmful interference when the equipment is operated in a commercial environment. This equipment generates, uses, and can radiate radio frequency energy and, if not installed and used in accordance with the instruction manual, may cause harmful interference to radio communications. Operation of this equipment in a residential area is likely to cause harmful interference in which case the user will be required to correct the interference at his own expense.

This Class A digital apparatus complies with Canadian ICES-003.
Cet appareil numérique de la classe A est conforme à la norme NMB-003 du Canada.

ISO 9001 Registration

In 1994, Ohaus Corporation, USA, was awarded a certificate of registration to ISO 9001 by Bureau Veritas Quality International (BVQI), confirming that the Ohaus quality management system is compliant with the ISO 9001 standard's requirements. On May 15, 2003, Ohaus Corporation, USA, was re-registered to the ISO 9001:2000 standard.

**TABLE OF CONTENTS**

1.	INTRODUCTION	EN-3
1.1	Description	EN-3
1.2	Features	EN-3
1.3	Safety Precautions	EN-3
2.	INSTALLATION	EN-4
2.1	Unpacking	EN-4
2.2	Installing Components	EN-4
2.2.1	Assembly of Models AV412, AV812, AV2101, AV2102, AV3102, AV4101, AV4102, AV8101	EN-4
2.2.2	Assembly of Models AV64, AV114, AV213, AV264, AV313, AV413	EN-5
2.2.3	Assembly of Model AV53	EN-8
2.2.4	Assembly of Models AV212	EN-9
2.3.	Selecting the Location	EN-9
2.4	Leveling the Balance	EN-9
2.5	Connecting Power	EN-10
2.5.1	AC Adapter	EN-10
2.5.2	Battery Installation	EN-10
2.5.3	Turning Power On and Off	EN-10
2.6	Initial Calibration	EN-10
3.	OPERATION	EN-12
3.1	Overview of Controls & Display Functions	EN-12
3.1.1	Models AV53, AV212, AV412, AV812, AV1502, AV2101, AV4101, AV8101	EN-12
3.1.2	Models AV64, AV64C, AV114, AV114C, AV212C, AV213, AV213C, AV313C, AV264, AV264C, AV412C, AV413, AV413C, AV812C, AV2101C, AV2102, AV2102C, AV3101C, AV3102, V4101C, AV4102, AV4102C, AV8101C	EN-12
3.2	Button Control Functions	EN-14
3.3	Using the Button Control Functions	EN-15
3.3.1	Setting the Balance to Zero	EN-15
3.3.2	Taring	EN-15
3.3.3	Changing Units of Measure	EN-15
3.3.4	Changing Application modes	EN-15
3.3.5	Printing Data	EN-15
3.4	Menu	EN-16
3.4.1	Menu Structure	EN-16
3.4.2	Menu Navigation	EN-17
3.4.3	Changing Settings	EN-17



TABLE OF CONTENTS (Cont.)

- 3.5 Application Modes EN-18
 - 3.5.1 Weighing EN-18
 - 3.5.2 Parts Counting EN-18
 - 3.5.3 Percent Weighing EN-19
 - 3.5.4 Check Weighing EN-20
 - 3.5.5 Animal Weighing EN-21
 - 3.5.6 Display Hold EN-22
 - 3.5.7 Totalize EN-23
- 3.6 Additional Features EN-23
 - 3.6.1 Weigh Below EN-23
 - 3.6.2 Battery Operation EN-24
- 3.7 Balance Settings EN-25
 - 3.7.1 Calibration EN-25
 - 3.7.2 Calibration Masses EN-30
 - 3.7.3 Setup EN-31
 - 3.7.4 Readout EN-31
 - 3.7.5 Mode EN-31
 - 3.7.6 Unit EN-32
 - 3.7.7 Print-1 and Print-2 EN-32
 - 3.7.8 RS232-1 and RS232-2 EN-33
 - 3.7.9 GLP Data EN-34
 - 3.7.10 GLP Print EN-35
 - 3.7.11 Reset EN-35
 - 3.7.12 Lockout EN-36
 - 3.7.13 End EN-36
- 3.8 Legal for Trade (LFT) EN-36
- 3.9 Sealing Access to the Balance Settings EN-37
- 3.10 Printing Data EN-37

- 4. MAINTENANCE EN-38
 - 4.1 Calibration EN-38
 - 4.2 Cleaning EN-38
 - 4.3 Troubleshooting EN-38
 - 4.4 Service Information EN-39
 - 4.5 Parts EN-39
 - 4.6 Accessories EN-40

- 5. TECHNICAL DATA EN-41
 - 5.1 Drawings EN-42
 - 5.2 Specifications EN-44
 - 5.3 Capacity x Readability EN-47
 - 5.4 Communication EN-50
 - 5.4.1 Commands EN-50
 - 5.4.2 Connections EN-51

- Limited Warranty EN-52



1 INTRODUCTION

This manual contains installation, operation and maintenance instructions for the Ohaus Adventurer Pro balances. Please read the manual completely before using the balance.

1.1 Description

The Adventurer Pro balances are precision weighing instruments that will provide you with years of service if properly cared for. The Adventurer Pro balances are available in capacities from 51 grams to 8100 grams.

1.1.1 Model Name Designations

Example: AV214CDR

AV = Product family abbreviation Adventurer Pro

214 = 210g model with 0.0001g readability

C = With internal calibration (INCAL)

D = Dual range model

R = 2nd interface installed (RS232)

U = 2nd interface installed (USB)

1.2 Features

The Adventurer Pro balances include many standard features. These include:

- Battery* or AC Adapter operation (AC Adapter included)
- Weighing, Parts Counting, Percent Weighing, Check Weighing, Animal Weighing Display Hold and Totalize application modes.
- In-use cover
- RS232 interface
- Integral security bracket
- Weigh below hook

* Battery operation is only available on certain models.

The Adventurer Pro also offers several optional features

- Internal Calibration
- USB interface
- Second RS232 Interface

1.3 Safety Precautions

Please follow these safety precautions:

- Verify that the input voltage printed on the AC Adapter matches the local AC power supply.
- Use the balance only in dry locations.
- Do not operate the balance in hostile environments.
- Do not drop loads on the platform.
- Do not place the balance upside down, without first installing the cone cover.
- Service should be performed only by authorized personnel.



2 INSTALLATION

2.1 Unpacking

Carefully remove your Adventurer Pro balance and each of its components from the package. Save the packaging to ensure safe storage and transport.

2.2 Installing Components

Use the illustrations and instructions below to identify and assemble your Adventurer Pro model with its components. All components must be installed before using the balance.

2.2.1 Assembly of Models AV412, AV812, AV2101, AV2102, AV3102, AV4101, AV4102, AV8101

Note: Assembly instructions also apply to models with the suffix C, CR, CU, R or U.

1. Insert the Sub-platform on the Mounting Cone located in the center of the balance. Align the Sub-platform so that it is fully seated on the cone.
2. Place the Weighing Pan on the Sub-platform.
3. For applicable Adventurer Pro models, place the Wind Ring over the pins located on the perimeter of the balance.

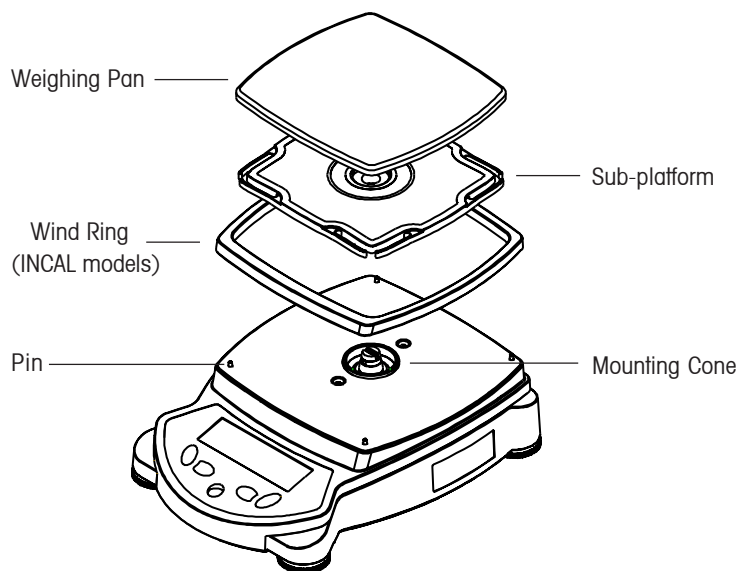



2.2.2 Assembly of Models AV64, AV114, AV213, AV264, AV313, AV413

Note: Assembly instructions also apply to models with the suffix C, CR, CU, R or U.

1. Insert the Platform Assembly on the Mounting Cone in the center of the balance.
2. Carefully remove each of the five (5) glass Draft Shield sections from its packing. You will note that two (2) of these are plain, two (2) contain handles, and the other is set in a plastic frame. These sections or panels comprise the front and rear, side doors, and top (respectively) of the Draft Shield. The Draft Shield contains four (4) upright posts and two (2) cross-members which act as a framework for insertion of the panels.
3. Install the plain glass panels to form the front and rear of the Draft Shield.
 - Select a plain glass panel and insert the bottom edge of the glass in the recessed slot in front of the balance, as shown.
 - As you push the top edge of the glass panel toward the cross-member, reach inside the top of the framework and depress the small clip located under the cross-member.
 - Press the glass panel into the framework until you feel the glass slip into place.
 - Release the clip when the glass panel is fully inserted.
 - Repeat these steps to install the other plain glass panel on the opposite side of the framework.

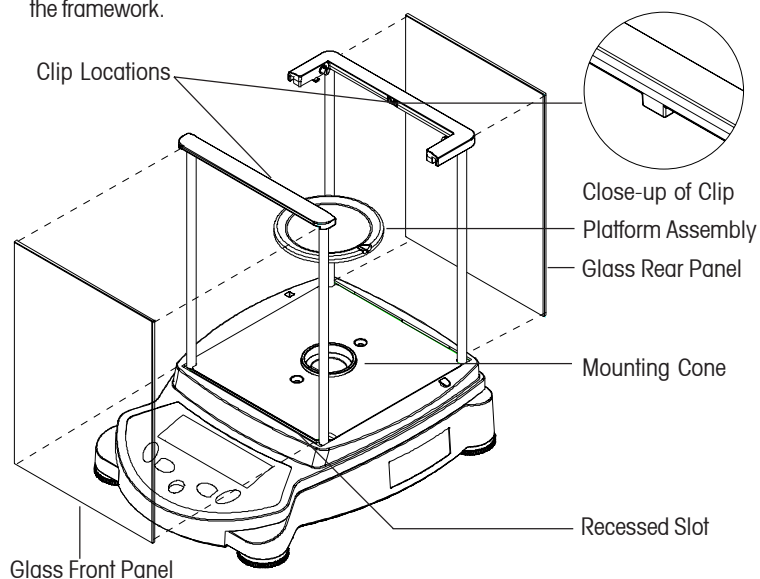



2.2.2 Assembly of Models AV64, AV114, AV213, AV264, AV313, AV413 (Cont.)

4. Install the glass doors in the sides of the Draft Shield framework.

Note: The glass doors must be inserted in the Draft Shield framework before inserting the top door; likewise, you must remove the top door before you remove the side doors.

- Hold and position each door so that the handle is near the front of the balance and the small notch on the bottom edge of the door is lined up with the tab that protrudes from the side of the balance housing (shown below).
 - Insert the top edge of the glass door into the recessed area under the top cross-member of the Draft Shield framework.
 - Slide the notch on the bottom edge over the tab and slip the door in place.
5. The door may now be opened by sliding it toward the back of the balance.

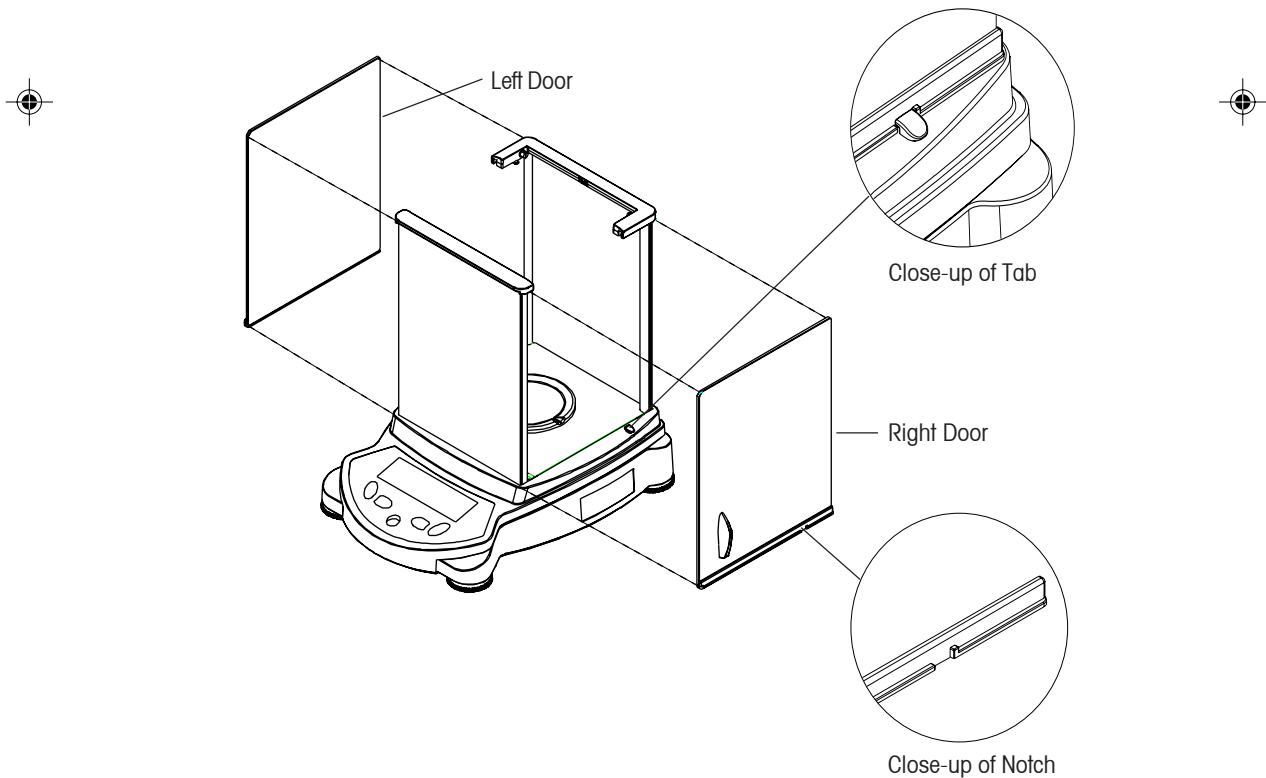



2.2.2 Assembly of Models AV64, AV114, AV213, AV264, AV313, AV413 (Cont.)

6. Install the top door panel.

- Insert the top door in the Draft Shield by holding the door vertically over the top of the Draft Shield framework, as shown.
- Position the back edge of the door so that it lines up with two small hinges located on the rear cross-member.
- Gently press the door on to the hinges, until it snaps into place.
- Tilt the door forward to close.

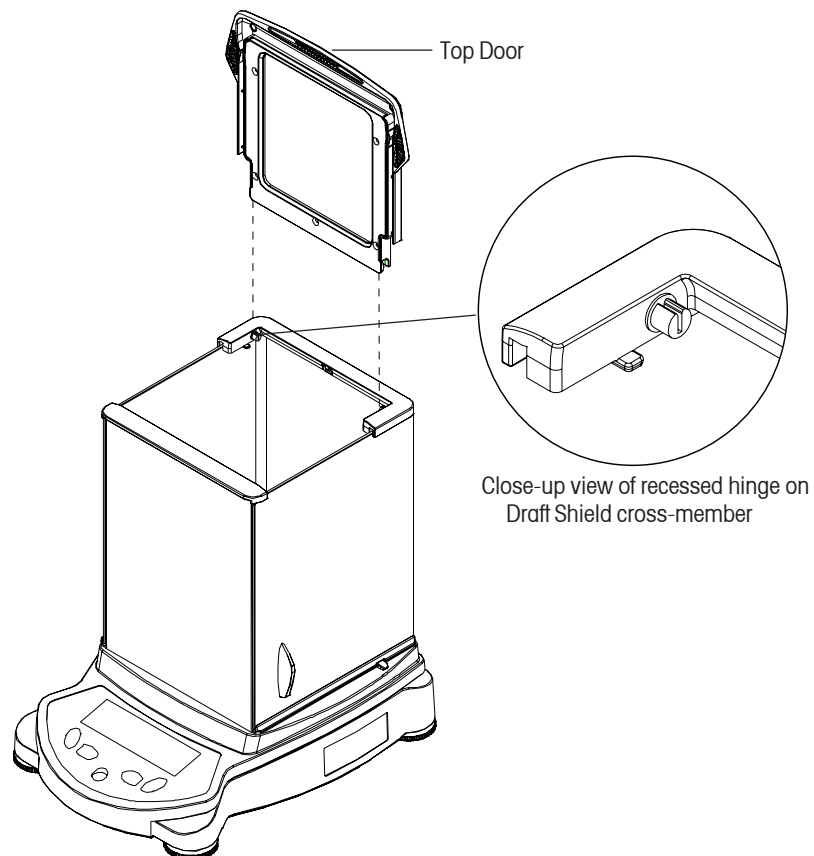



2.2.3 Assembly of Model AV53

Note: Assembly instructions also apply to models with the suffix C, CR, CU, R or U.

1. Insert the Sub-platform on the mounting cone in the center of the balance.
2. Place the Weighing Pan on the Sub-platform.
3. Attach the Draft Shield by inserting the round bottom edge in the circular recessed slot, as shown.
4. Place the metal cover on top of the Draft Shield.

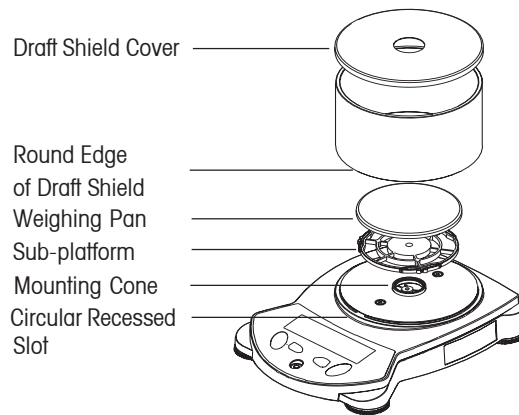



2.2.4 Assembly of Models AV212

Note: Assembly instructions also apply to models with the suffix C, CR, CU, R or U.

1. Insert the Sub-platform on the Mounting Cone located in the center of the balance.
2. Place the Weighing Pan on the Sub-platform.
3. Place the Wind ring over the shoulder of the balance.

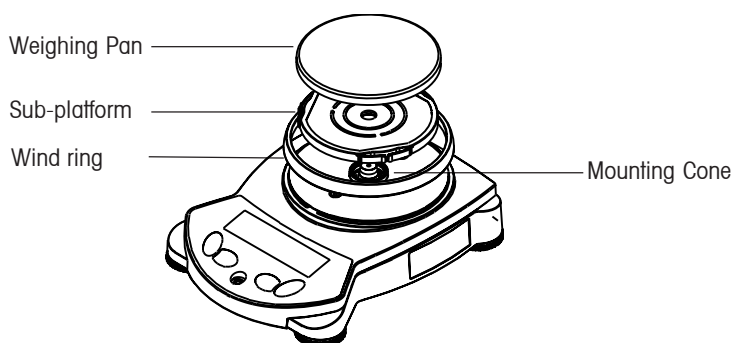

2.3 Selecting the Location

Locate the balance on a firm, steady surface. Avoid locations with excessive air current, vibrations, heat sources, or rapid temperature changes.

2.4 Leveling the Balance

Before the balance is used, the feet should be adjusted so that the scale is level with the surface. This will enable accurate weighing. You will see a level bubble indicator in a small round window on the front of the balance. Level the balance by adjusting the leveling feet so the bubble is centered in the circle, as seen below.

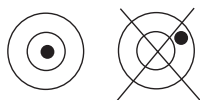

Balance Level

2.5 Connecting Power

2.5.1 AC Adapter

Connect the AC Adapter to the wall outlet. Connect the plug into the receptacle on the rear of the balance.



For use with CSA Certified (or equivalent approved) power source, which must have a limited circuit output.

2.5.2 Battery Installation

Some Adventurer Pro models operate with batteries. To install batteries, remove the pan and its components and install the cone cover to protect the load cell.

CAUTION:

To protect the balance from damage while installing batteries, make sure the cone cover is in place.

Remove the battery compartment cover from the bottom of the balance. Install 4 AA (LR6) batteries in the compartment, aligning the batteries according to the + and - symbols. With the balance in an upright position, remove the cone cover and re-install the pan and its components.

2.5.3 Turning Power On and Off

Press the **On/Zero** button to turn power on.

The balance performs a segment check. The balance then displays the last selected application mode.



To turn power off, press and hold the **Off** button until OFF is displayed, then release the button.



2.6 Initial Calibration

When the balance is first installed, and when it is moved to another location, it must be calibrated to ensure accurate weighing results. Have the appropriate calibration masses available before beginning calibration. Refer to Section 3.7.1 for masses and calibration procedure.





3 OPERATION

3.1 Overview of Controls & Display Functions

3.1.1 Models AV53, AV212, AV412, AV812, AV2101, AV4101, AV8101

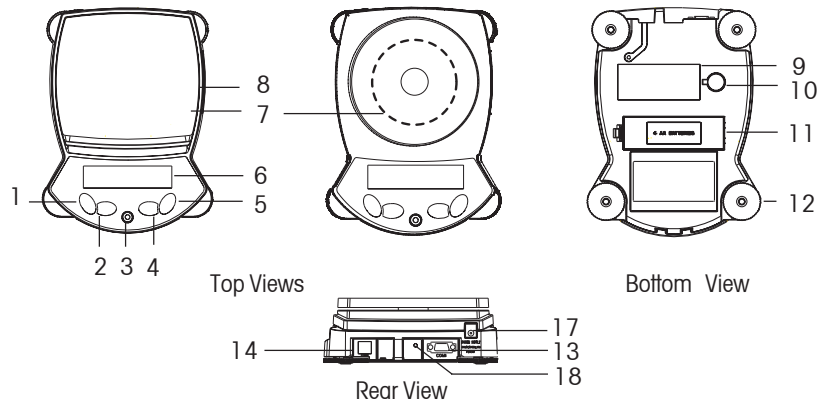

3.1.2 Models AV64, AV64C, AV114, AV114C, AV212C, AV213, AV213C, AV313, AV313C, AV264, AV264C, AV412C, AV413, AV413C, AV812C, AV2101C, AV2102, AV2102C, AV3101C, AV3102, AV4101C, AV4102, AV4102C, AV8101C

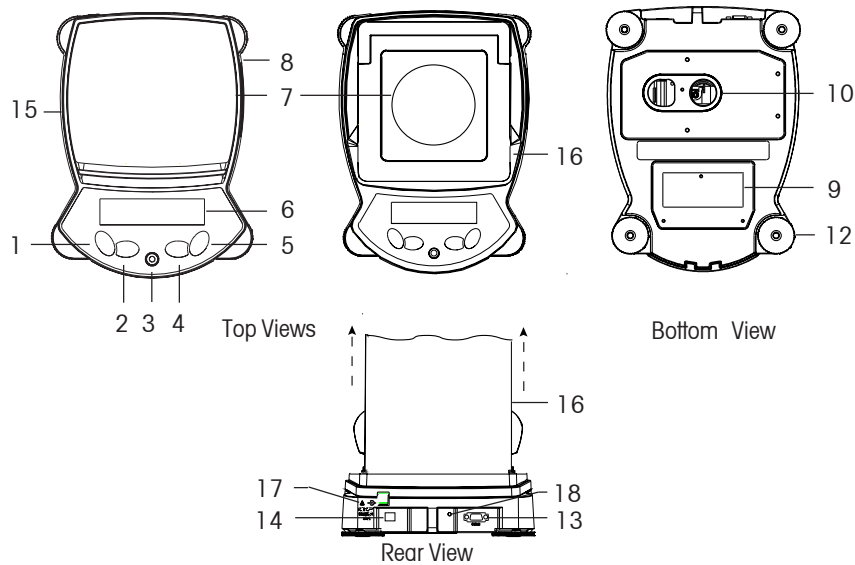

3.1 Overview of Controls and Display Functions (Cont.)

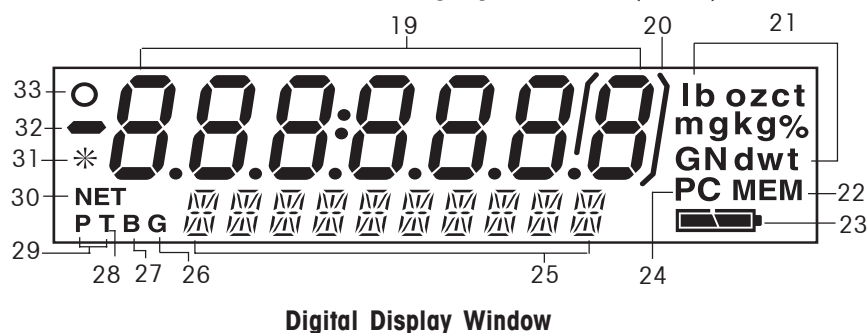
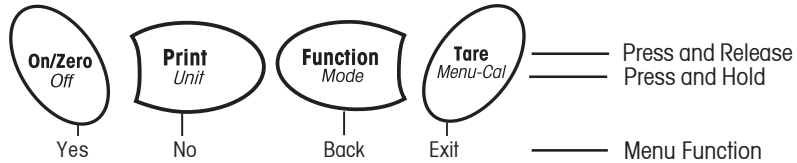

TABLE 3.1-1 ADVENTURER PRO CONTROLS AND DISPLAY FUNCTIONS.

No.	Description	No.	Description
1	On / Zero / Off / Yes Button	18	Lock Switch
2	Print Unit / No Button	19	Primary (7 segment) display
3	Level Bubble	20	Brackets
4	Function Mode / Back button	21	Units of Measurement
5	Tare Menu-Cal / Exit Button	22	Memory Indicator
6	Display	23	Battery Strength Indicator
7	Pan	24	Pieces Indicator
8	Type label on side of housing	25	Secondary (14 Segment) Display
9	Data label	26	Gross Indicator
10	Weigh Below Opening	27	Brutto Indicator
11	Battery Compartment	28	Tare Indicator
12	Leveling feet	29	Preset Tare Indicator
13	COM 1 Connector	30	Nef Indicator
14	COM 2 Connector (AV...R and AV...J Models only)	31	Stability Indicator
15	Wind Ring	32	Negative Indicator
16	Draft Shield	33	Center of Zero Indicator
17	Power Connector		

3.2 Button Control Functions

Four multifunction buttons are used to operate the balance and navigate the menus. The function of each button is shown below.



Primary Function	On/Zero <ul style="list-style-type: none"> • If balance is off, turns balance on. • If balance is on, sets zero. 	Print <ul style="list-style-type: none"> • Sends current display value to the serial interface. 	Function <ul style="list-style-type: none"> • Operation is dependent on the application mode. 	Tare <ul style="list-style-type: none"> • Performs tare operation.
Secondary Function	<i>Off</i> <ul style="list-style-type: none"> • Turns balance off. 	<i>Unit</i> <ul style="list-style-type: none"> • Change weighing unit. 	<i>Mode</i> <ul style="list-style-type: none"> • Change application mode. 	<i>Menu-Cal</i> <ul style="list-style-type: none"> • Enter the User menu. Calibration is the first sub-menu.
Menu Function	Yes <ul style="list-style-type: none"> • Accepts the current (blinking) setting on the display. 	No <ul style="list-style-type: none"> • Rejects the current setting (blinking) on the display. • Increments a value being entered. 	Back <ul style="list-style-type: none"> • Reverts back to previous menu item. • Decrements a value being entered. 	Exit <ul style="list-style-type: none"> • Immediately exits menu mode. • Aborts a calibration in progress.



3.3 Using the Button Control Functions

3.3.1 Setting the Balance to Zero

Remove the load from the pan and press the **Zero** button to set the display to zero.

When the weighing pan or platform is empty, The Center of Zero indicator turns on when the measurement is within $\pm 1/4$ d of the zero setting.

3.3.2 Taring

Taring refers to the action of allowing for the weight of a container so that only the weight of objects held in the container (net weight) is displayed.

To Tare

Place the empty container on the pan and press the **Tare** button.

Add material to the container. The net weight of the material is displayed.

To clear the Tare value, remove the container from the pan and press the **Tare** button.

Auto Tare

Auto Tare automatically compensates for container weight so the balance displays net weight.

Auto Tare must be set ON in the Setup sub-menu (See Section 3.7.2 Setup Sub-menu).

The secondary display shows PLACE CONTAINER (blinking). When the container is placed on the pan, it is automatically tared and Net weight is displayed. The Tare value is automatically cleared when the container is removed from the pan.

Preset Tare

Use the xT command in the command table to enter a preset tare value through a computer.

To clear the Tare value, enter a value of 0.0. See Section 5.4.1.

3.3.3 Changing Units of Measure

The Adventurer Pro can be configured to measure in a variety of units, including custom units. The Unit Sub-menu is used to enable or disable a specific unit.

To select a unit of measure:

Press and hold the **Unit** button, then release it when the desired unit is displayed.

Note: If the desired unit is not displayed, it must be turned on in the Unit menu (See Section 3.7.5).

3.3.4 Changing Application Modes

The Adventurer Pro can be configured to operate in various application modes. The Mode Sub-menu is used to enable or disable a specific application mode.

Press and hold the **Mode** button and release it when the desired mode is shown on the secondary display. **Note:** If the desired mode is not displayed, it must be turned on in the Mode menu. See Section 3.7.4.

3.3.5 Printing Data

Press the **Print** button to send the displayed value to the COM port (See Section 3.10).

Note: The port must have Auto Print set to OFF.

3.4 MENU

3.4.1 Menu Structure

The Adventurer Pro balance menu structure is illustrated below.

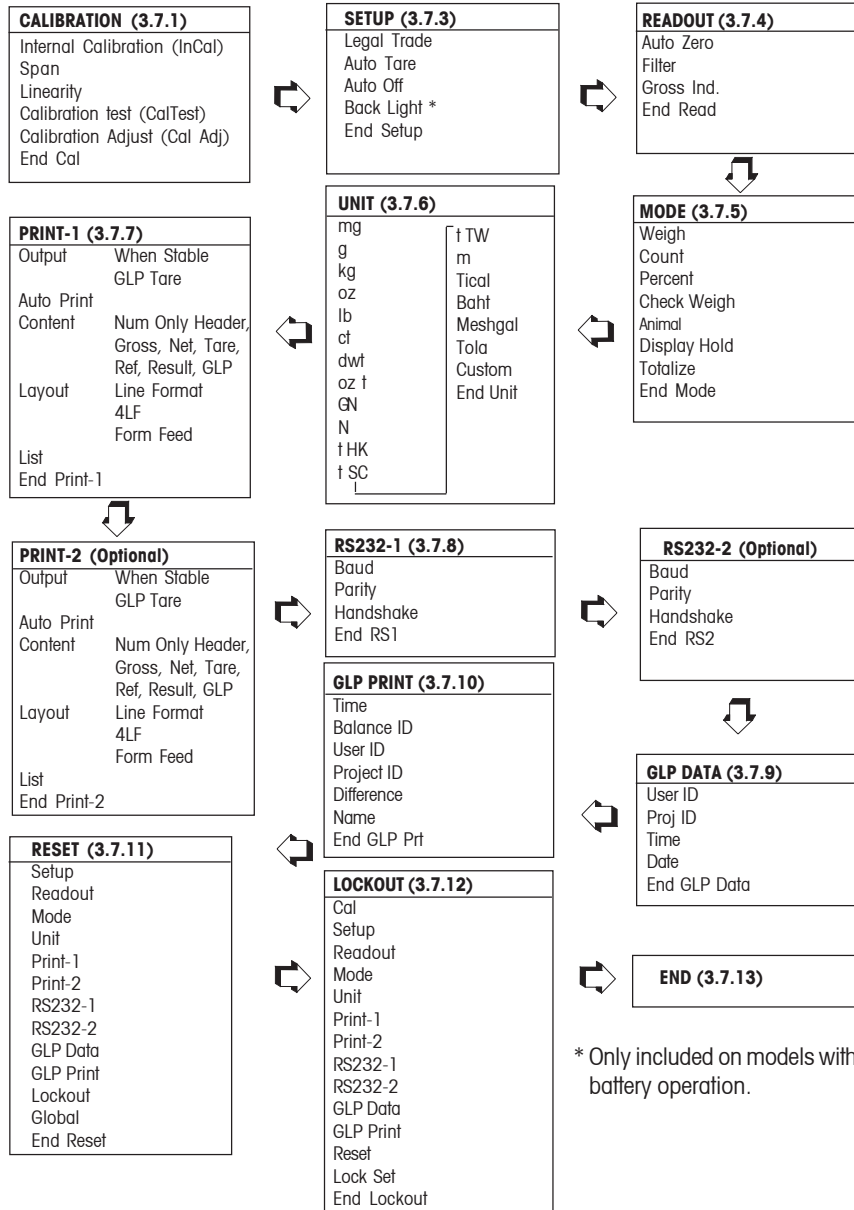

* Only included on models with battery operation.

3.4.2 Menu Navigation

The Adventurer Pro menu structure consists of three levels. The top level is the main menu which consists of a number of sub-menus.

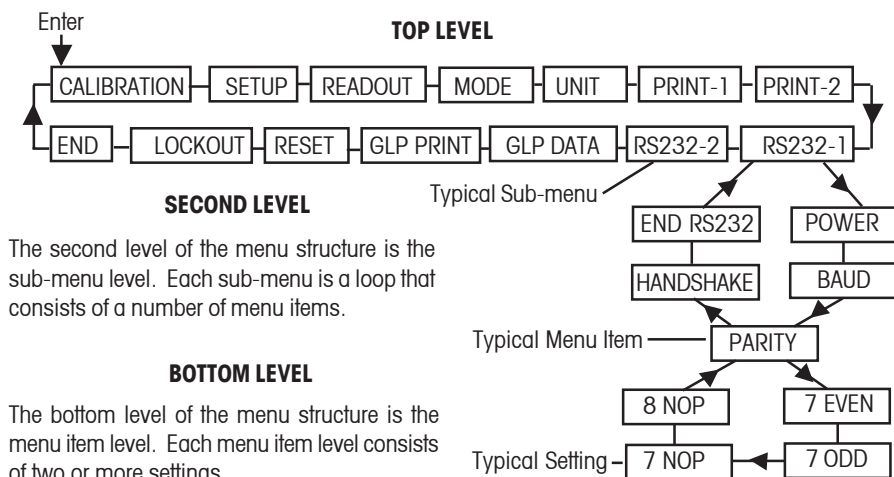

The second level of the menu structure is the sub-menu level. Each sub-menu is a loop that consists of a number of menu items.

The bottom level of the menu structure is the menu item level. Each menu item level consists of two or more settings

3.4.3 Changing Settings

To change a menu setting, perform the following steps:

ENTER THE MENU

Press and hold the **Menu** button until MENU appears on the primary (7-Segment) display. Release the button and the first sub-menu appears on the secondary (14-Segment) display (blinking).

Note: When the secondary display is blinking, press **Yes** to accept. Press **No** or **Back** or view another selection.

SELECT THE SUB-MENU

Press the **No** button to select the next sub-menu or the **Back** button to select the previous sub-menu in the loop. Press the **Yes** button to select the sub-menu that appears on the secondary display (blinking). The sub-menu name now appears on the primary display and the first menu item in the sub-menu now appears on the secondary display (blinking).

SELECT THE MENU ITEM

Press the **No** button to select the next setting or the **Back** button to select the previous setting in the loop. Press the **Yes** button to select and save the setting on the secondary display (blinking) as the new menu item setting.

EXIT THE MENU

Press the **Exit** button at any time to quickly exit the menu or select END sub-menu and press the **Yes** button.



3.5 Application Modes

The Adventurer Pro balance incorporates Weighing, Parts Counting, Percent Weighing, Check Weighing, Animal Weighing, Display Hold and Totalize application modes. The default setting has the weighing mode turned on and all other application modes turned off.

Note: Before using any application modes, they must be turned on in the Mode menu (See Section 3.3.4).

3.5.1 Weighing

Use this mode to determine the weight of items in the selected unit of measure. The Adventurer Pro is shipped with grams enabled. Before using other units of measure, these units must be turned on in the Unit menu (See Section 3.7.5).

Weigh

Press and hold **Mode** until the display shows WEIGH, then release the button.

Press **Zero** to zero the balance.

Place objects to be weighed on the pan to display the weight.

The example displays a 200 gram weight.



3.5.2 Parts Counting

Use the Parts Counting Mode to count samples of uniform weight.

Press and hold **Mode** until Count is displayed, then release the button.

Establish an Average Piece Weight (APW).

Each time a new type of part is counted, the nominal weight of one piece (Average Piece Weight) must be established using a small quantity of pieces. This APW is stored until replaced by another APW.



If an APW has already been established, Count is displayed with Clear APW? blinking.

Press **No** to use the previously saved APW.

Otherwise, press **Yes** to establish a new APW.



The current weight (0.00) is shown on the primary display and the default sample size (PLACE 10) is shown on the secondary display.



To change the sample size, press and hold the **No** button to increment the sample size through the range of 1 to 100. Release the button when the desired sample size appears on the secondary display.





3.5.2 Parts Counting (Cont.)

Place the specified number of parts on the pan.
 Press the Function button to accept. The primary display will now indicate the number of parts. The weight is shown on the secondary display.

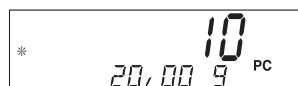

Pressing the **Function** button momentarily displays the APW on the secondary display. The example shows an APW of 2.000g.



Clearing the APW

Press and hold the **Mode** button until COUNT is shown on the secondary display.

APW Optimization

The only adjustment for Parts Counting is APW Optimization. APW Optimization is set On or Off in the Mode menu when Parts Counting is turned On. When APW Optimization is set on, the APW is automatically optimized. This results in more accurate parts counting. The factory default is On. When a new APW has been established, APW Optimization occurs when the number of pieces added to the pan are between one and three times the number already on the pan. The secondary display will momentarily indicate APW OPT.

3.5.3 Percent Weighing

Use the Percent Weighing Mode to measure the weight of a sample as a percentage of a pre-established reference weight. Refer to Section 3.3.4 to enable Percent Weighing.

Press and hold the **Mode** button. When PERCENT displays, release the button. The primary display shows PERCENT. If a Reference Weight is stored in memory, the secondary display shows CLEAR REF? (blinking). Press **No** to use the stored reference weight and begin Percent Weighing. Press **Yes** to clear the saved Reference Weight.



Establishing a Reference Weight

If no Reference Weight is stored, a Reference Weight must be established. The secondary display shows PUT SAMPLE. The current weight is shown on the primary display.





3.5.3 Percent Weighing (Cont.)

Place the sample on the pan and press the **Function** button. This example illustrates 50 grams as the reference weight.

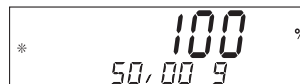

Remove the reference weight and place the item to be compared on the pan. The balance indicates the actual percentage on the primary display. The secondary display indicates the weight in the selected measuring unit.

Pressing the **Function** button momentarily displays the reference weight on the secondary display.

Clearing the Reference Weight

Press and hold the **Mode** button until PERCENT is shown on the secondary display.

3.5.4 Check Weighing

Check Weighing is used to compare the weight of a sample against target limits.

Press and hold the **Mode** button. When Check Weighing is displayed, release the button. If Check Weighing limits previously have been set and stored in memory, the secondary display shows Edit REF? (blinking). Press **No** to use the stored limits and begin Check Weighing, or press **Yes** to set Check Weighing limits.



Setting Under and Over Limits

The primary display shows UNDER or OVER indicating which limit is being entered. The secondary display shows the previous setting or all zeros if no limit was stored (blinking). Press the **Yes** button to accept this setting. Press the **No** button to edit this setting. The Under limit is the first to be edited, followed by the Over limit.





3.5.4 Check Weighing (Cont.)

Editing Limits

The limits are edited one digit at a time. The digit being edited is blinking. Its value can be incremented by pressing the **No** button or decremented by pressing the **Back** button. When the desired value is displayed, press the **Yes** button to accept the value and proceed to the next digit. When all digits have been edited, the new limit value is shown (blinking) on the secondary display. Press the **Yes** button to accept the new limit value or the **No** button to edit the limit value. When editing of the Over limit is complete, Check Weighing begins. Place the sample on the pan. The UNDER/ACCEPT/OVER status is shown on the primary display while the actual weight of the item is shown on the secondary display.



3.5.5 Animal Weighing

Enter this mode to weigh an unstable load, such as a moving animal. Refer to Section 3.4.3 to enable Animal Weighing.

Press and hold **Mode**. Release **Mode** when ANIMAL is displayed. The balance alternately shows READY and ANIMAL on the secondary display.



Automatic and Semi-Automatic Mode

The animal cycle begins when an animal is placed on the pan.



Manual Mode

The animal cycle begins when the **Function** button is pressed.

During Animal Cycle

The primary display shows the countdown from the level setting (5, 10 or 15 seconds) to AWO. The secondary display alternately shows ANIMAL and BUSY.





3.5.5 Animal Weighing (Cont.)

Completed Animal Cycle

The primary display shows the weight of the animal and the secondary display alternates between ANIMAL and HOLD.

Automatic Mode

The balance returns to the Ready condition when the animal is removed from the pan. If the **Function** button is pressed before the animal is removed from the pan, the primary display shows the actual weight and the secondary display alternates between ANIMAL and CLEAR PAN until the animal is removed from the pan. The balance then returns to the Ready condition.

Semiautomatic and Manual Modes

Remove the animal from the pan and press the **Function** button to return to the Ready condition. If the **Function** button is pressed while the animal is on the pan, the primary display shows the actual weight and the secondary display alternates between ANIMAL and CLEAR PAN. The balance returns to the Ready condition when the animal is removed from the pan. The Animal Weigh level and mode settings are made in the Mode menu.

3.5.6 Display Hold

The Display Hold Mode allows the user to capture and store the highest (stable) weight in a series of weight measurements. The Display Hold Mode provides the user with three (3) operating modes: Automatic, Semi-automatic and Manual.

Automatic Mode :

Highest stable weight captured automatically.
Ready for next measurement automatically when pan is cleared.

Semi-Automatic Mode :

Highest stable weight captured automatically. Ready for next measurement after pressing FUNCTION key.

Manual Mode :

Press **Function** button to take measurement. Ready for next measurement after pressing **Function** button.

Clear Peak :

Press and hold **Function** button - release when Mode>DISP/HOLD appears. In all modes, the actual weight is shown on the primary display when READY or CLEAR PAN is shown on the secondary display. The current Peak value is shown on the primary display when HOLD is shown on the secondary display. Display icons annunciate weighing unit, stability and center of zero when actual weight is displayed. The weighing unit only is annunciated when the Peak weight is displayed.

3.5.7 Totalize

Totalize measures the cumulative weight of items. Refer to Section 3.4.3 to enable totalizing. Press **Mode**, then release the button when Totalize is displayed. The primary display shows the current weight. The secondary display alternates between TOTALIZE and the current totalized weight.

Adding Weight to the Total Automatic Mode

Place the item on the weighing pan. The weight of the item is shown on the primary display. The weight of the item is added automatically to the total weight and the new total is shown on the secondary display. Remove the item from the weighing pan, then add the next item.



Manual Mode

Place the item on the weighing pan. The weight of the item is shown on the primary display. Press the **Function** button to add the weight of the item to the total. The new total is shown on the secondary display. Remove the item from the weighing pan, then add the next item.



Clearing the Totalized Weight

Press and hold the **Mode** button until TOTALIZE is shown on the secondary display.



3.6 Additional Features

3.6.1 Weigh Below

The Adventurer Pro balance is equipped with a weigh below hook.

Note: Before turning the balance over, install the cone cover to prevent damage to the loadcell.

To use this feature, remove power from the balance and remove the protective cover for the weigh below opening.

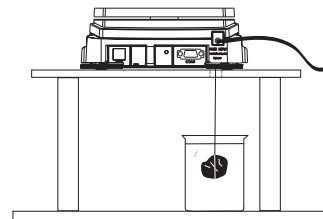





The balance can be supported using lab jacks or any other convenient method. Make sure the balance is level and secure. Use a string or wire to attach items to be weighed.



3.6.2 Battery Operation

Refer to Section 5.2 to determine if your Adventurer Pro model operates on battery power when AC power is not supplied. Models with the battery operation feature will display the battery charge indicator, as shown below. If batteries are installed and AC power is not present, the balance operation is affected as follows:

- The LCD backlight is normally off to conserve power. The backlight turns on when the display becomes unstable or when a button is pressed. The backlight turns off 5 seconds after the display becomes stable or after 5 seconds with no button presses. The backlight is always off if the Backlight menu setting is OFF.
- Auto Off is set to 5 minutes. If continuous operation is desired, change the Auto Off menu setting to Off.
- The battery charge level is annunciated by means of a three segment battery symbol on the display as follows:

Full charge	
2/3 charge	
1/3 charge	
Replace batteries	 (Flashing)



3.7 Balance Settings

Refer to Section 3.4.2 to enter and navigate the menus.

3.7.1 Calibration

Adventurer Pro balances offer a choice of five calibration methods: Internal Calibration (InCAL™), Span Calibration, Linearity Calibration, Calibration Test™ and Calibration Adjust.

- **InCal™** - For models equipped with Internal calibration (InCAL™), calibration of the balance is accomplished by an internal mass.
- **Span** - Span calibration ensures that the balance reads correctly within specifications using two weight values: zero and a weight value between 25% and 100% of the balance's capacity.
- **Linearity** - Linearity calibration minimizes deviation between actual and displayed weights within the balance's weighing range. Three weight values are used: zero, a weight value at midpoint of the balance's weighing range, and a weight value at or near the balance's specified capacity.
- **Cal Test** - Calibration test allows the stored calibration data to be tested against the current mass being used for the test.
- **Cal Adj** - For models equipped with InCal™, allows adjustment of the internal calibration.

Notes: Calibration may be locked out to prevent unauthorized personnel from changing calibration. If calibration has been locked out, you can only access Cal Test on InCal™ models.

Before beginning calibration, have masses available. Masses required for calibration are listed in the table in section 3.7. 2. Default Span Calibration Points are shown in Bold print.

Internal Calibration (InCal models)

Models equipped with the internal calibration can be calibrated without using an external weight. With the balance on, press and hold the **Menu-Cal** button until MENU CALIBRATE is displayed, then release the button.

Press **Yes** to initiate the internal calibration process. When internal calibration is finished, the balance returns to the currently selected mode.

Span Calibration

With the balance on, press and hold the **Menu-Cal** button until MENU is displayed, then release the button. CALIBRATE (blinking) is displayed.

Note: If the balance has InCal, press the **No** button to advance to span calibration.

Press the **Yes** button to enter span calibration.
Press the **Yes** button to initiate span calibration.

First the zero reading is taken. Next the display shows the default span calibration weight value.

Press **No** to change to an alternate calibration weight. Press **Yes** when the desired calibration weight is displayed.

Place the specified calibration weight on the platform. After calibration, remove the weight from the platform.

To abort calibration at any time, press the **Exit** button.



Linearity Calibration

NOTICE:



Linearity Calibration is required only if the linearity error exceeds tolerance in specification table.

With the balance on, press and hold the **Menu-Cal** button until MENU CALIBRATE is displayed, then release the button. CALIBRATE (blinking).



Press the **Yes** button to enter calibration.

Note: If the balance has InCal, press the **No** button to advance to linearity calibration. CAL LINEARITY (blinking) is displayed.

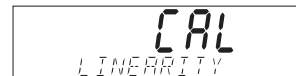

Press the **Yes** button and follow the screen instructions. Use the weight values shown on the primary display.

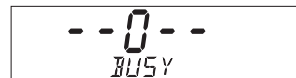

First the zero reading is taken. Next the display shows the first calibration weight value. PUT WEIGHT (blinking) is displayed. Place the specified calibration weight on the platform.

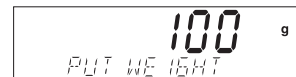

After a few seconds, place the second specified calibration weight on the platform. PUT WEIGHT (blinking) is displayed. After a few seconds, the calibration weight is displayed.

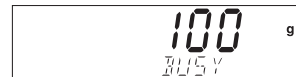

LINEAR DONE is momentarily displayed when calibration is completed.

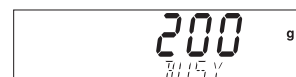

After calibration, remove weight from platform. To leave the menu, press **Exit**.



To abort calibration at any time, press the **Exit** button.





Calibration Test (InCal models)

Calibration test allows a check of a known calibration mass against the last stored calibration information in the balance.



Press and hold the **Menu-Cal** button until MENU CALIBRATE is displayed.

Press **Yes** to enter calibration.

Press **No** until CAL TEST is displayed.



Press **Yes** and follow the screen instructions.

Place the specified weight on the platform. After a short period, the display indicates the difference in weight from the last calibration, and then will display the calibration weight on the platform. After the test, remove the calibration weight from the platform. To leave the menu, press **Exit**.



(Example)



Calibration Adjust (InCal models)

Calibration Adjust may be used to adjust the result of the internal calibration by ± 100 divisions.

Note: Before making a calibration adjustment, perform an internal calibration. To verify whether an adjustment is needed, place a test mass on the platform and note the difference (in divisions) between the nominal mass value and the actual reading. Refer to Section 3.7.2 and use the highest value from the Span Calibration Points column as the test mass. If the difference is within ± 1 division, calibration adjustment is not required. If the difference exceeds ± 1 division, calibration adjustment is recommended. Following a calibration adjustment, repeat the internal calibration and verification procedures.

To perform a calibration adjustment, press the **Menu-Cal** button and release it when MENU CALIBRATE is displayed.



Press **Yes** to enter the Calibration sub-menu. Press **No** until CAL ADJ is displayed.

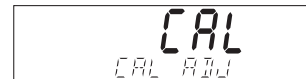

Press **Yes** to enter the CAL ADJ menu item and view the current setting. If the actual reading was less than the nominal mass value, a positive adjustment is required. Press **No** until the setting matches the difference noted earlier in the procedure. If the actual reading was greater than the nominal mass value, a negative adjustment is required. Press **Back** until the setting matches the difference noted earlier in the procedure. Press **Yes** to accept and store the setting.

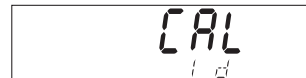

3.7.2 Calibration Masses

Model	Linearity Calibration Points	Span Calibration Points (1)	Weight Class	
			ASTM	OIML
AV53	25g / 50g	30g, 40g, 50g	2	F1
AV64	20g / 50g	40g, 50g , 60g	1	E2
AV114	50g / 100g	50g / 100g	1	E2
AV212	100g / 200g	50g, 100g, 150g, 200g	2	F1
AV213	100g / 200g	100g, 200g	1	E2
AV264	150g / 250g	200g, 250g	1	E2
AV313	150g / 300g	150g, 200g, 250g, 300g	1	E2
AV412	200g / 400g	100g, 200g , 300g, 400g	2	F1
AV413	200g / 400g	200g, 300g, 400g	1	E2
AV812	400g / 800g	200g, 300g, 400g, 500g , 600g, 700g, 800g	2	F1
AV2101	1000g / 2000g	500g, 1000g, 1500g, 2000g	2	F1
AV2102	1000g / 2000g	1000g, 2000g	1	E2
AV3102	2000g / 3000g	1000g, 2000g, 3000g	1	E2
AV4101	2000g / 4000g	1000g, 2000g , 3000g, 4000g	2	F1
AV4102	2000g / 4000g	2000g, 3000g, 4000g	1	E2
AV8101	4000g / 8000g	2000g, 3000g, 4000g, 5000g , 6000g, 7000g, 8000g	2	F1

3.7.3 Setup

SETUP	
Legal Trade	On/ Off
Auto Tare	On/ Off
Auto Off	Off , 1, 2, 5 min
Back Light	On/Off
End Setup	

Legal Trade

When set On, the balance operates in compliance with Weights and Measures regulations.

Auto Tare

When set On, the balance will automatically tare the first item placed on the pan.

Auto Off

When set to 1, 2 or 5 minutes, the balance will turn off in the selected time interval if there has been no activity. Set to OFF for continuous operation.

Back Light

Used to set the display back light on or off. This sub-menu is only included on models with battery operation.

End Setup

Press the **Yes** button, to advance to the Readout submenu. Press the **No** button to return to the LEGAL TRADE menu item.

3.7.4 Readout

READOUT	
Auto Zero	Off, .5d , 1d, 2d, 5d
Filter	Low, Medium , High
Gross Ind.	G, B, Off
End Read	

Auto Zero

Allows setting the balance auto zero level setting: .5, 1, 2 or 5 divisions. Balance maintains zero until threshold is exceeded.

Filter

Allows setting the balance filter level: Low, Medium, High. Compensates for vibration or excessive air currents.

Gross Ind.

Allows setting the gross indicator to G (gross), B (brutto) or Off.

End Read

Press the **Yes** button to advance to the Mode submenu. Press **No** to return to Auto Zero.

3.7.5 Mode

The Mode submenu is used to turn Application modes On or Off.

MODE	
Weigh	On/Off
Count	On/ Off └Apw Optimize On/Off
Percent	On/ Off
Check Weigh	On/ Off
Animal	<u>Auto</u> , <u>Semi</u> , <u>Man</u> , Off └Level sec 5,10, 15
Display Hold	Off, Auto, Semi, man
Totalize	On/ Off
End Mode	

Weigh

Use to set the Weighing Mode On or Off.

Count

Use to set the Counting Mode On or Off. If Count is set On, APW optimize can be set On or Off.

Percent

Allows setting the percent weighing mode On or Off.

Check Weigh

Use to set the Check Weighing Mode On or Off.

Animal

Use to set the Animal Weighing Mode to: Auto, Semi, Manual or Off. If set to Auto, Semi or Manual, level (averaging period) can be set to 5, 10 or 15 seconds.

Display Hold

Use to set the Display Hold Mode to Auto, Semi-automatic or Manual.

Enter the Factor, following the instructions for Editing Limits in Section 3.5.4. Enter the Exponent and LSD using the **Yes No** buttons.

Totalize

Use to set the Totalize Mode to Auto, Manual or Off.

End Mode

Press the **Yes** button to advance to the Unit submenu. Press **No** to return to Weigh.

Factor	Exponent (+3 to -3)	Conversion Factor
.1234	3	123.4
.1234	2	12.34
.1234	1	1.234
.1234	0	.1234
.1234	-1	.01234
.1234	-2	.001234
.1234	-3	.0001234

3.7.6 Unit

The Unit submenu is used to turn measuring units On or Off. Available measuring units vary by model.

Custom Unit = Conversion Factor x Grams.

UNIT			
mg	On/Off	†TW	On/Off
g	On/Off	m	On/Off
kg	On/Off	Tical	On/Off
oz	On/Off	Baht	On/Off
lb	On/Off	Meshgal	On/Off
ct	On/Off	Tola	On/Off
dwt	On/Off	Custom	On/Off
ozt	On/Off	End Unit	
GN	On/Off		
N	On/Off		
†HK	On/Off		
†SC	On/Off		

The LSD is the value by which the displayed weight is incremented or decremented.

LSD	Result
.5	Adds one decimal place Display counts by 5
1	Display counts by 1
2	Display counts by 2
5	Display counts by 5
10	Display counts by 10
100	Display counts by 100

Defining Custom Unit

Set Custom to ON in the Unit menu to enable and define the Custom Unit. The custom unit is defined by a conversion factor and a least Significant Digit (LSD). The conversion factor is used by the balance to convert grams to the custom weighing unit and is defined by entering a factor and an exponent. The factor is a value between 0.1000000 and 1.999999 inclusive. The exponent moves the decimal point of the factor to the right for positive values or to the left for negative values.

End Unit

Press the **Yes** button to advance to the Print-1 submenu. Press **No** to return to the first available unit.

3.7.7 Print-1 and Print-2

The Print-1 submenu is used to set printing parameters for an external printer or computer.

Print-2 contains an identical menu and is used when the optional COM2 port is installed.



3.7.7 Print-1 and Print-2 (Cont.)

PRINT-1		
Output	When Stable	On/Off
	GLP Tare	On/Off
Auto Print	Off, Cont., Interval, When Stable	1 -3600 seconds
Content	Stable- Load, Load & Zero	Num Only-Off, all others
		On-Header, Gross, Net, Tare, Ref, Result, GLP
Layout	Line Format	Multi, Single
	4LF-Yes/No	Form Feed-Yes/No
List	Yes/No	
End Print-1		

Output

Set When Stable to On to print only stable values. Set When Stable to Off to print stable or unstable values.

Set GLP Tare to On to print GLP data once after a tare operation. Set GLP Tare to Off to disable this feature.

Auto Print

When set to Continuous, the displayed value is printed continuously. When set to Interval, the displayed value is printed at the user specified time interval (1 to 3600 seconds).

If set to When Stable, the balance will automatically print the displayed value when stability is achieved. An additional setting must be made to determine if only stable non-zero values will be printed (load setting) or if stable zero and non-zero values will be printed (Load & Zero). When set to Off, the Auto print feature is disabled.

Content

All of these features can be set On or Off. Numeric data only, Header, Gross, Net, Tare, Reference, Result, GLP. (See sample printout 3.10)

Layout

Determines the format of data output to a printer or computer. If Line Format is set to Multi, a multi-line printout is generated. If it is set to Single, a single line printout is generated. If 4 LF is set to yes, 4 line feeds are appended to the printout. If Form feed is set to Yes, a form feed is appended to the printout. This is useful for printing to page printers.

List

When Yes is selected, a printout of balance settings is generated.

End Print-1

Press the **Yes** button to advance to the next menu, Print-2 if COM2 is installed or RS232-1 if COM2 is not installed. Pressing **No** returns to Output menu item.

3.7.8 RS232-1 and RS232-2

The RS232-1 submenu is used to set communication parameters for an external printer or computer.

RS232-2 contains an identical menu and is available when the optional COM2 port is installed.

RS232-1	
Baud	600..2400...19200
Parity	7 Even, 7 Odd, 7 No Par , 8 No Parity
Handshake	Off, XONXOFF Hardware
End RS1	



3.7.8 RS232-1 and RS232-2 (Cont.)

When the balance is operated from batteries, the menu item is available and the default setting is Off. To enable COM1, Power must be turned On.

Baud

Baud rates of 600, 1200, 2400, 4800, 9600 and 19,200 are available.

Parity

Parity settings of 7 even, 7 Odd, 7 No Parity and 8 No Parity are available.

Handshake

Settings of Off, XONXOFF and (for RS232-1 only) Hardware are available.

End RS1 (RS2)

Pressing the **Yes** button will advance to the RS232-2 (or GLP Data) submenu. Pressing **No** returns to the Power (or Baud) menu item.

3.7.9 GLP Data

GLP DATA	
User ID	Set...
Proj ID	Set...
Time	Type- 12hr , 24hr, Set..., Adj-60, +60
Date	Type mdy ,...dym Set...
End GLP Data	

User ID

Used to enter a User ID up to 10 characters.

Project ID

Used to enter a Project ID up to 10 characters.

Entering a User ID or Project ID

Enter the user or Project ID one character at a time. The character to be entered is highlighted by a blinking cursor (underscore). Press the **No** button repeatedly to scroll through the list of available characters: (space), -, 0 through 9, A through Z. Press the **Yes** button to select the displayed character and move the cursor one position to the right. After the tenth character is entered, the ten character ID will blink. Press the **No** button to change the displayed ID or the Yes button to accept the ID and proceed to the next menu item.

Time

Type

Set the type to 12 hours or 24 hours.

Set

Set the current time using the format selected in the type menu item.

Adjust

Enter an adjustment value from -60 to + 60 seconds per day.

Date

Set the date type: M/D/Y, D/M/Y, Y/M/D, M/Y/D, Y/D/M, D/Y/M and the actual date.

End GLP Data

Press the **Yes** button to advance to the GLP Print submenu. Press the **No** button to return to User ID.



3.7.10 GLP Print

Select GLP items to be printed by setting them to On.

GLP PRINT	
Time	On/Off
Balance ID	On/Off
User ID	On/Off
Project ID	On/Off
Difference	On/Off
Name	On/Off
End GLP Prt	

End GLP Print

Press the **Yes** button to advance to the reset submenu. Press the **No** button to return to Time.

3.7.11 Reset

RESET	
Setup	RESET?
Readout	RESET?
Mode	RESET?
Unit	RESET?
Print-1	RESET?
Print-2	RESET?
RS232-1	RESET?
RS232-2	RESET?
GLP Data	RESET?
GLP Print	RESET?
Lockout	RESET?
Global	RESET?
End Reset	

Setup

Select Yes to return all Setup menu items to their factory settings.

Readout

Select Yes to return all Readout menu items to their factory settings.

Mode

Select Yes to return all Mode menu items to their factory settings.

Unit

Select Yes to return all Unit menu items to their factory settings.

Print-1

Select Yes to return all Print-1 menu items to their factory settings.

Print-2 (If COM2 is installed)

Select Yes to return all print-2 menu items to their factory settings.

RS232-1

Select Yes to return all RS232-1 menu items to their factory settings.

RS232-2 (If COM2 is installed)

Select Yes to return all RS232-2 menu items to their factory settings.

GLP Data

Select Yes to return all GLP Data menu items to their factory settings.

GLP Print

Select Yes to return all GLP Print menu items to their factory settings.

Lockout

Select Yes to return all Lockout menu items to their factory settings.

Global

Select Yes to return the menu items in all sub-menus to their factory settings.

End Reset

Press the **Yes** button to advance to the Lockout menu. Press the **No** button to return to Setup.



3.7.12 Lockout

Use this submenu to prevent unauthorized changes to menu settings. If a submenu is locked, its menu item settings can be viewed but not changed.

LOCKOUT	
Cal	On/Off
Setup	On/Off
Readout	On/Off
Mode	On/Off
Unit	On/Off
Print-1	On/Off
Print-2	On/Off
RS232-1	On/Off
RS232-2	On/Off
GLP Data	On/Off
GLP Print	On/Off
Reset	On/Off
Lock Set	On/Off
End Lockout	

Cal

Set On to lock and hide the Calibration Menu.

Setup

Set On to lock the Setup Menu.

Readout

Set On to lock the Readout Menu.

Mode

Set On to lock the Mode Menu.

Unit

Set On to lock the Unit Menu.

Print-1/2

Set On to lock the Print-1/2 Menu.

RS232-1/2

Set On to lock the RS232-1/2 Menu.

GLP Data

Set On to lock the GLP Data Menu.

GLP Print

Set On to lock the GLP Print Menu.

Reset

Set On to lock the Reset Menu.

Lock Set

Set On to lock all submenu lock settings. When set Off, the lock settings for all menus are accessible. To turn Lock Set off, refer to section

End Lockout

Press the **Yes** button to advance to the End menu. Press the **No** button to return to the Cal menu.

3.7.13 End

The End menu is used to exit the menus and return to previous application

3.8 Legal for Trade (LFT)

Specific Adventurer Pro models have been designed to comply with OIML, EEC, NTEP and Measurement Canada weights and measures regulations. Contact Ohaus for further details about availability.

When the LEGAL TRADE menu item setting is set to ON, the following conditions apply:

- The CALIBRATION menu is hidden.
- The LEGAL TRADE menu item is hidden.
- The AUTO ZERO menu item setting is set to 0.5d and locked.
- The OUTPUT WHEN STABLE menu item setting is set to ON and locked.
- The CONTINUOUS setting in the AUTO PRINT menu item is hidden.



3.9 Sealing Access to the Balance Settings

When used in conjunction with the Lockout menu, the balance may be sealed to prevent or detect unauthorized changes to the balance settings. For legal or trade applications, the balance must be sealed to prevent access to the metrological parameters.

To seal the balance, cover the Lock switch access hole at the rear of the balance. A paper seal, and a wire seal may be installed as shown.



To regain access to the locked balance settings, break the seal and press the recessed Lock switch momentarily while OHAUS is displayed during power up.

Sealing the Balance

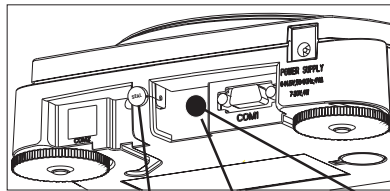

Wire Seal Paper Seal Lock Switch (Under Seal)
Rear of the Balance

3.10 Printing Data

Printing data to an external computer or printer requires that the communication parameters in the RS232-1 and/or RS232-2 submenus be set to match external device communication parameters.

```

04/01/05 12:30 PM // if GLP SET> Time is ON
Bal ID 1234567 // if GLP SET> Balance ID is ON
USER ID ABCDEFGHIJ // if GLP SET> User ID is ON
PROJ ID 1234567890 // if GLP SET> Proj ID is ON
Name..... // if GLP SET > Name is ON
// If a tare value is entered, these three items are printed if selected in the definition string.
0.0200kg G // Gross ON - G, B or [space] as determined in Readout submenu.
0.0200kg T // Tare ON
0.0000kg NET // Net ON
// Otherwise, gross is printed if selected in the definition string.
0.0200kg G // Gross ON - G, B or [space] as determined in Readout submenu.

```

4. MAINTENANCE

4.1 Calibration

Periodically verify calibration by placing an accurate weight on the balance and if calibration is required, refer to section 3.7.1.

4.2 Cleaning

If cleaning is required, use a soft cloth dampened with water and a mild detergent. Do not allow liquids to enter the balance. Do not use harsh chemicals to clean the balance, as the finish may be damaged.

4.3 Troubleshooting

The following table lists common problems, possible causes and remedies. If the problem persists, contact Ohaus or your authorized Ohaus dealer.

Symptom	Possible Cause	Remedy
Balance will not turn on	<ul style="list-style-type: none"> AC power not connected Batteries discharged 	<ul style="list-style-type: none"> Connect AC adapter Replace batteries
Battery indicator is flashing	<ul style="list-style-type: none"> Batteries are weak 	<ul style="list-style-type: none"> Replace batteries
Balance does not display accurately	<ul style="list-style-type: none"> Improper calibration Unstable environment 	<ul style="list-style-type: none"> Perform calibration Move balance to a suitable location
Cannot calibrate the balance	<ul style="list-style-type: none"> Calibration menu locked LFT set to on Unstable weight reading 	<ul style="list-style-type: none"> Turn Calibration menu lock off Turn LFT off Eliminate vibration and drafts.
Cannot change Menu settings	<ul style="list-style-type: none"> Submenu locked LFT set to on 	<ul style="list-style-type: none"> Unlock submenu Turn LFT off
Error 7.0	<ul style="list-style-type: none"> Unstable weight reading when defining the reference weight. 	<ul style="list-style-type: none"> Eliminate vibration and drafts.
Error 8.1	<ul style="list-style-type: none"> Weight reading exceeds Power On Zero limit. 	<ul style="list-style-type: none"> Clear platform.
Error 8.2	<ul style="list-style-type: none"> Weight reading below Power On Zero limit. 	<ul style="list-style-type: none"> Put platform on balance.
Error 8.3	<ul style="list-style-type: none"> Weight reading exceeds overload limit. 	<ul style="list-style-type: none"> Clear platform.
Error 8.4	<ul style="list-style-type: none"> Weight reading below underload limit. 	<ul style="list-style-type: none"> Put platform on balance.
Error 9.0	<ul style="list-style-type: none"> Internal fault. 	<ul style="list-style-type: none"> Return balance for service.

4.3 Troubleshooting (Cont.)

Symptom	Possible Cause	Remedy
Error 9.5	<ul style="list-style-type: none"> Production calibration not present. 	<ul style="list-style-type: none"> Return balance for service.
Error 9.8	<ul style="list-style-type: none"> user calibration data not present. (Required for LFT ON only) 	<ul style="list-style-type: none"> Calibrate balance.
Error 53	<ul style="list-style-type: none"> EEPROM checksum error. 	<ul style="list-style-type: none"> Cycle power on, off. If balance fails to operate, return for service.
LOW REF WT	<ul style="list-style-type: none"> Average piece weight too small. (Warning) 	<ul style="list-style-type: none"> See section 3.5.3.
REF WT Err	<ul style="list-style-type: none"> Reference weight too small The weight on the pan is too small to define a valid reference weight. 	<ul style="list-style-type: none"> Increase sample size.
-----	<ul style="list-style-type: none"> Busy (tare, zero, printing) 	<ul style="list-style-type: none"> Wait until completion.

4.4 Service Information

If the Troubleshooting section does not resolve or describe your problem, contact your authorized Ohaus Service Agent. For Service assistance or technical support in the United States, call toll-free 1-800-526-0659 between 8:00 AM and 5:00 PM EST. An Ohaus product service specialist will be available to provide assistance. Outside the USA, please visit our web site, www.ohaus.com to locate the office nearest you.

4.5 Parts

<u>Description</u>	<u>Ohaus Part Number</u>
AC adapters	
Output: 12 VAC 500 mA	
• US 120V/60Hz	12102320
• Euro 230V/50Hz	12102321
• UK 230V/50Hz	12102322
• Australia 230V/50Hz	12102323
Output: 9 VDC 500 mA	
• Japan 100V/50Hz	12102324



4.5 Parts (Cont.)

<u>Description</u>	<u>Ohaus Part Number</u>
In-Use Cover Kit (10 x 7.6 in. / 25.4 x 19.3 cm housing)	12103980
In-Use Cover Kit (11.8 x 8.7 in. / 30 x 22 cm housing)	12103857
Top Door Kit	12103873
Glass Door Kit (8.7 in. / 22 cm draftshield)	12103645
Glass Door Kit (5 in. / 12.5 cm draftshield)	12103646
Replacement Pans	
• Round pan (3.5 in. / 9 cm diameter)	12103856
• Round pan (3.9 in. / 10 cm diameter)	12102939
• Round pan (4.7 in. / 12 cm diameter)	12102940
• Rectangular pan (5.8 x 6.3 in. / 14.9 x 16.2 cm)	12103941
• Rectangular pan (7.6 x 8 in. / 19.3 x 20.3 cm)	12103880

4.6 Accessories

Security device	76288-01
RS232 Cables	
• Cable, DB9M-DB9F	80500525
• Cable, DB9M-DB25F	80500524
• Cable, DB9M-SF42 Printer	80500571
• Cable, DB9M-Apple	80500562
SF42 Printer	SF42

5. TECHNICAL DATA

Ambient conditions

The technical data are valid under the following ambient conditions:

- Ambient temperature: 10 °C to 30 °C
- Relative humidity: 15 % to 80 % at 31 °C non-condensing, decreasing linearly to 50 % at 40 °C
- Height above sea level: Up to 2000 m

Operability is assured at ambient temperatures between 5 and 40 °C

Power

- AC adapter - To national standard as per list in Section 4.6. Balance power input 6-14.5 VAC, 50/60Hz 4VA or 7-20VDC, 4W
- Batteries - 4 x AA (LR6) 1.5 V (not included), typical 20 h with alkaline batteries.

Materials

- Housing base: plastic (ABS/PC)
- Top Housing: plastic (ABS/PC)
- Platform: 18/10 stainless steel

Protection

- Protected against dust and water
- Pollution degree: 2
- Installation category: Class II
- EMC: see declaration of conformity



5.1 Drawings

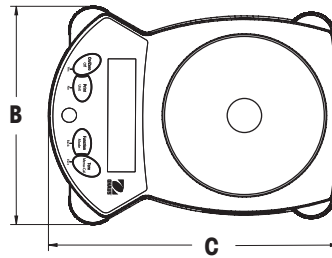
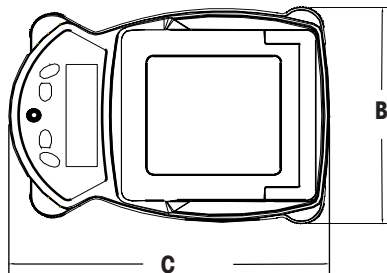
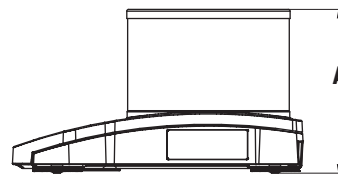
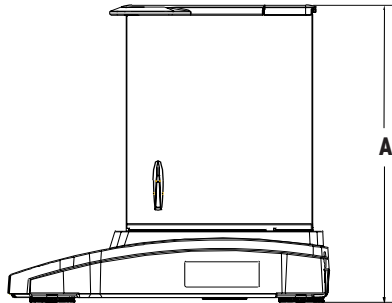

Figure 5-1

Figure 5-2

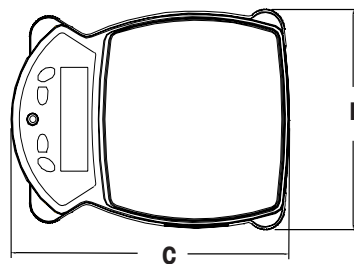
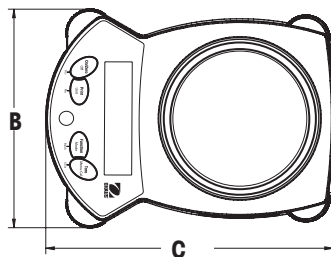
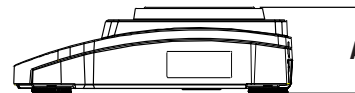
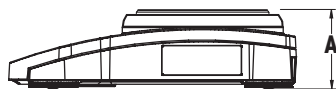

Figure 5-3

Figure 5-4

Note: See table on next page for model designations and dimensions.

**5.1 Drawings (Cont.)**

FIGURE	MODELS	A	B	C
		OVERALL HEIGHT	OVERALL WIDTH	OVERALL DEPTH
5-1	AV64, AV64C, AV114, AV114C, AV264, AV264C	30 cm 12 in.	22 cm 8.7 in.	30 cm 11.8 in.
	AV213, AV213C, AV313, AV313C, AV413, AV413C	19 cm 7.5 in.	22 cm 8.7 in.	30 cm 11.8 in.
5-2	AV53	14.5 cm 5.7 in.	19.3 cm 7.6 in.	25.4 cm 10 in.
5-3	AV212, AV412, AV812, AV2101, AV4101, AV8101	7.2 cm 2.8 in.	19.3 cm 7.6 in.	25.4 cm 10 in.
5-4	AV212C, AV412C, AV812C, AV2101C, AV2102, AV2102C, AV3102, AV3102C AV4101C, AV4102,	8.5 cm 3.3 in.	22 cm 8.7 in.	30 cm 11.8 cm



5. TECHNICAL DATA

5.2 Specifications

Item Number	AV53*	AV 64 AV 64C**	AV114 AV114C**	AV264 AV264C**	AV213 AV213C**	AV313 AV313C**	AV413 AV413C**	AV212*	AV412*
Capacity (g)	51	65	110	260	210	310	410	210	410
Readability (g)	0.001		0.0001			0.001			0.01
Repeatability (Std.dev.)(g)	0.001		0.0001			0.001			0.01
Linearity (g)	±0.002		±0.0002	±0.0003		±0.002			±0.02
Weighing Units	Milligram, Gram, Kilogram, Ounce, Pound, Carat, Pennyweight, Ounce Troy, Grain, Newton, Hong Kong Tael, Singapore Tael, Taiwan Tael, Momme, Tical, Bah, Mesghal, Tola, Custom								
Application Modes	Weighing, Parts Counting, Percent Weighing, Check Weighing, Animal Weighing, Display Hold, Totalize								
Tare Range	To Capacity by Subtraction								
Stabilization Time (s)	2.5			3					2
Draft - Shield Height Over Platform	2.75/7		8.6/22			4.5/11.5			---
Power Requirements	AC Adapter (Included)								
Calibration	Digital with External Weight								
Display Type	2-Line LCD w/Backlight								
Display Size (in/cm)	4 x 1 / 10 x 2.5								
Platform Size (in/cm)	3.9 / 10		3.5 / 9 dia.				4.7 / 12 dia.		5.8 x 6.3 / 14.9 x 16.2
Dimensions W x H x D (in/mm)	7.6 x 5.7 x 10 / 19.3 X 14.5 X 25.4		8.7 x 12 x 11.8 / 22 x 30 x 30			8.7 x 7.5 / 11.8 / 22 x 19 x 30		7.6 x 2.8 x 10 / 19.3 x 7.2 x 25.4	
Net Weight (lb/kg)	3.1 / 1.4		8.7 / 4.0			7.3 / 3.3		2.6 / 1.2	3.3 / 1.5
Net Weight (with (InCal) (lb/kg)	--		9.6 / 4.4			8.2 / 3.7		--	--

* Also operates on 4 AA batteries (not included)

** Internal calibration option available (C) models.

5. TECHNICAL DATA (Cont.)
5.2 Specifications (Cont.)

Item Number	AV812*	AV212C**	AV412C**	AV812C**	AV2102 AV2102C**	AV3102 AV3102C**	AV4102 AV4102C**	AV2101*	AV4101*
Capacity (g)	810	210	410	810	2100	3100	4100	2100	4100
Repeatability (g)	0.01								
Repeatability (Std.dev.)(g)	0.01								
Linearity (g)	± 0.02								
Weighing Units	Milligram, Gram, Kilogram, Ounce, Pound, Carat, Pennyweight, Ounce Troy, Grain, Newton, Hong Kong Tael, Singapore Tael, Taiwan Tael, Momme, Tical, Baht, Mesghal, Tola, Custom								
Application Modes	Weighing, Parts Counting, Percent Weighing, Check Weighing, Animal Weighing, Display Hold, Totalize								
Tare Range	To Capacity by Subtraction								
Stabilization Time (s)	2					3		2	
Power Requirements	AC Adapter (Included)								
Calibration	Digital with External Weight								
Display Type	2-Line LCD w/Backlight								
Display Size (in/cm)	4 x 1 / 10 x 2.5								
Platform Size (in/cm)	5.8 X 6.3 X / 14.9 X 16.2		4.7 / 12 dia.		6.6 x 7.1 / 16.8 x 18		6.6 X 7.1 / 16.8 X 18 non InCal model without draft ring		5.8 X 6.3 X / 14.9 X 16.2
Dimensions W x H x D (in/mm)	7.6 x 2.8 x 10 / 19.3 X 7.2 X 25.4		8.7 x 3.3 x 11.8 / 22 x 8.5 x 30				7.6 x 2.8 x 10 / 19.3 x 7.2 x 25.4		
Net Weight (lb/kg)	3.3 / 1.5		--		6.1 / 2.8		3.5 / 1.6		
Net Weight (with InCal) (lb/kg)	--		5.7 / 2.6		7.5 / 3.4		6.9 / 3.2		--

* Also operates on 4 AA batteries (not included)
 ** Internal calibration option available (C) models.

5. TECHNICAL DATA (Cont.)

5.2 Specifications (Cont.)

Item Number	AV8101*	AV2101C**	AV4101C**	AV8101C**
Capacity (g)	8100	2100	4100	8100
Repeatability (g)	0.1			
Repeatability (Std.dev.)(g)	0.1			
Linearity (g)	± 0.2			
Weighing Units	Milligram, Gram, Kilogram, Ounce, Pound, Carat, Pennyweight, Ounce Troy, Grain, Newton, Hong Kong Tael, Singapore Tael, Taiwan Tael, Momme, Tical, Bant, Mesghal, Tola, Custom			
Application Modes	Weighing, Parts Counting, Percent Weighing, Check Weighing, Animal Weighing, Display Hold, Totalize			
Tare Range	To Capacity by Subtraction			
Stabilization Time (s)	2			
Power Requirements	AC Adapter (Included)			
Calibration	Digital with External Weight Internal calibration			
Display Type	2-Line LCD w/Backlight			
Display Size (in/cm)	4 x 1 / 10 x 2.5			
Platform Size (in/cm)	5.8 x 6.3 / 14.9 x 16.2			
Dimensions W x H x D (in/mm)	7.6 x 2.8 x 1.0 / 19.3 x 7.2 x 25.4			
Net Weight (lb/kg)	3.5 / 1.6			
Net Weight (with InCal) (lb/kg)	--			

* Also operates on 4 AA batteries (not included)
 ** Internal calibration option available (C) models.



5.3 Capacity x Readability

Unit	AV53	AV64 AV64C	AV114 AV114C	AV264 AV264C	AV213 AV213C	AV313 AV313C
bahf	3.3553 x 0.0001	4.27632 x 0.00001	7.23684 x 0.00001	17.10526 x 0.00001	13.8158 x 0.0001	20.3947 x 0.0001
carat	255.000 x 0.005	325.0000 x 0.0005	550.0000 x 0.0005	999.995 / 1300.000 X 0.0005 / 0.001	1050.000 x 0.005	1550.000 x 0.005
grain	787.06 x 0.02	1003.104 x 0.002	1697.570 x 0.002	4012.414 x 0.002	3240.80 x 0.02	4784.03 x 0.02
gram	51.000 x 0.001	65.0000 x 0.0001	110.0000 x 0.0001	260.0000 x 0.0001	210.000 x 0.001	310.000 x 0.001
kilogram	0.051000 x 0.000001				0.210000 x 0.000001	0.310000 x 0.000001
mesghal	11.0670 x 0.0005	14.10485 x 0.00005	23.86990 x 0.00005	56.41975 x 0.00005	45.5700 x 0.0005	67.2699 x 0.0005
milligram	51000 x 1	65000.0 x 0.1	110000 x 0.1	260000.0 x 0.1	210000 x 1	310000 x 1
momme	13.6000 x 0.0005	17.33335 x 0.00005	29.33335 x 0.00005	69.33335 x 0.00005	56.0000 x 0.0005	82.6667 x 0.0005
Newton	0.50014 x 0.00001	0.637432 x 0.000001	1.078732 x 0.000001	2.549729 x 0.000001	2.05940 x 0.00001	3.04006 x 0.00001
ounce	1.79895 x 0.00005	2.292805 x 0.000005	3.880135 x 0.000005	9.171230 x 0.000005	7.40755 x 0.00005	10.93495 x 0.00005
ounce troy	1.63970 x 0.00005	2.089800 x 0.000005	3.536585 x 0.000005	8.359185 x 0.000005	6.75165 x 0.00005	9.96672 x 0.00005
pennyweight	32.794 x 0.001	41.7960 x 0.0001	70.7316 x 0.0001	167.1839 x 0.0001	135.033 x 0.001	199.335 x 0.001
pound	0.112435 x 0.000005				0.462970 x 0.000005	0.683432 x 0.000005
tael (Hong Kong)	1.36260 x 0.00005	1.736620 x 0.000005	2.938900 x 0.000005	6.946485 x 0.000005	5.61060 x 0.00005	8.28233 x 0.00005
tael (Singapore)	1.34925 x 0.00005	1.719605 x 0.000005	2.910100 x 0.000005	6.878420 x 0.000005	5.55555 x 0.00005	8.20110 x 0.00005
tael (Taiwan)	1.36000 x 0.00005	1.733335 x 0.000005	2.933335 x 0.000005	6.933335 x 0.000005	5.60000 x 0.00005	8.26667 x 0.00005
tical	3.1232 x 0.0001	3.98057 x 0.00001	6.73635 x 0.00001	15.92227 x 0.00001	12.8603 x 0.0001	18.9842 x 0.0001
tola	4.372 x 0.0001	5.57267 x 0.00001	9.43067 x 0.00001	22.29067 x 0.00001	18.0040 x 0.0001	26.5773 x 0.0001

5.3 Capacity x Readability (Cont.)

Unit	AV413 AV413C	AV212 AV212C	AV412 AV412C	AV812 AV812C	AV2102 AV2102C	AV3102 AV3102C
bath	26.9737 x 0.0001	13.816 x 0.001	26.974 x 0.001	53.289 x 0.001	138.158 x 0.001	203.947 x 0.001
carat	2050.000 x 0.005	1050.00 x 0.05	2050.00 x 0.05	4050.00 x 0.05	10500.00 x 0.05	15500.00 x 0.05
grain	6327.28 x 0.02	3240.8 x 0.2	6327.4 x 0.2	12500.2 x 0.2	32408.0 x 0.2	47840.3 x 0.2
gram	410.000 x 0.001	210.00 x 0.01	410.00 x 0.01	810.00 x 0.01	2100.00 x 0.01	3100.00 x 0.01
kilogram	0.410000 x 0.000001	0.21000 x 0.00001	0.41000 x 0.00001	0.81000 x 0.00001	2.10000 x 0.00001	3.10000 x 0.00001
mesghal	88.9695 x 0.0005	45.570 x 0.005	88.970 x 0.005	175.770 x 0.005	455.700 x 0.005	672.699 x 0.005
milligram						
momme	109.3335 x 0.0005	56.000 x 0.005	109.335 x 0.005	216.000 x 0.005	560.000 x 0.005	826.667 x 0.005
Newton	4.02073 x 0.00001	2.0594 x 0.0001	4.0207 x 0.0001	7.9434 x 0.0001	20.5940 x 0.0001	30.4006 x 0.0001
ounce	14.46230 x 0.00005	7.4075 x 0.0005	14.4625 x 0.0005	28.5720 x 0.0005	74.0755 x 0.0005	109.3495 x 0.0005
ounce Troy	13.18180 x 0.00005	6.7515 x 0.0005	13.1820 x 0.0005	26.0420 x 0.0005	67.5165 x 0.0005	99.6672 x 0.0005
pennyweight	263.636 x 0.001	135.03 x 0.01	263.64 x 0.01	520.84 x 0.01	1350.33 x 0.01	1993.35 x 0.01
pound	0.903895 x 0.000005	0.46295 x 0.00005	0.90390 x 0.00005	1.78575 x 0.00005	4.62970 x 0.00005	6.83432 x 0.00005
tael (Hong Kong)	10.95405 x 0.00005	5.6105 x 0.0005	10.9540 x 0.0005	21.6410 x 0.0005	56.1060 x 0.0005	82.8233 x 0.0005
tael (Singapore)	10.84675 x 0.00005	5.5555 x 0.0005	10.8465 x 0.0005	21.4290 x 0.0005	55.5565 x 0.0005	82.0120 x 0.0005
tael (Taiwan)	10.93335 x 0.00005	5.6000 x 0.0005	10.9335 x 0.0005	21.6000 x 0.0005	56.0000 x 0.0005	82.6667 x 0.0005
tical	25.1082 x 0.0001	12.860 x 0.001	25.108 x 0.001	49.604 x 0.001	128.603 x 0.001	189.842 x 0.001
tola	35.1507 x 0.0001	18.004 x 0.001	35.151 x 0.001	69.444 x 0.001	180.040 x 0.001	265.773 x 0.001



5.3 Capacity x Readability (Cont.)

Unit	AV4102 AV4102C	AV2101 AV2101C	AV4101 AV4101C	AV8101 AV8101
baht	269.737 x 0.001	138.16 x 0.01	269.74 x 0.01	532.89 x 0.01
carat	20500.00 x 0.05	10500.0 x 0.5	20500.0 x 0.5	40500.0 x 0.5
grain	63272.8 x 0.2	32408 x 2	63274 x 2	125002 x 2
gram	4100.00 x 0.01	2100.0 x 0.1	4100.0 x 0.1	8100.0 x 0.1
kilogram	4.10000 x 0.00001	2.1000 x 0.0001	4.1000 x 0.0001	8.1000 x 0.0001
mesghal	889.695 x 0.005	455.70 x 0.05	889.70 x 0.05	1757.70 x 0.05
milligram				
monme	1093.335 x 0.005	560.00 x 0.05	1093.35 x 0.05	2160.00 x 0.05
Newton	40.2073 x 0.0001	20.594 x 0.001	40.20 x 0.001	79.434 x 0.001
ounce	144.6230 x 0.0005	74.075 x 0.005	144.625 x 0.005	285.720 x 0.005
ounce troy	131.8180 x 0.0005	67.515 x 0.005	131.820 x 0.005	260.420 x 0.005
pennyweight	2636.36 x 0.01	1350. x 0.1	2636. x 0.1	5208.4 x 0.1
pound	9.03895 x 0.00005	4.6295 x 0.0005	9.0390 x 0.0005	17.8575 x 0.0005
tael (Hong Kong)	109.5405 x 0.0005	56.105 x 0.005	109.540 x 0.005	216.410 x 0.005
tael (Singapore)	108.4675 x 0.0005	55.555 x 0.005	108.465 x 0.005	214.290 x 0.005
tael (Taiwan)	109.3335 x 0.0005	56.00 x 0.005	109.335 x 0.005	216.000 x 0.005
tical	251.082 x 0.001	128.60 x 0.01	251.0 x 0.01	496.04 x 0.01
tola	351.507 x 0.001	180.04 x 0.01	351.51 x 0.01	694.4 x 0.01



5.4 Communication

The balance is equipped with an RS232 interface (COM1). Some models are also equipped with a second RS232 interface (COM2). Connecting the balance to a computer enables you to operate the balance from the computer, as well as receive data such as displayed weight.

5.4.1 Commands

Commands listed in the following table will be acknowledged by the balance. The balance will return "ES" for invalid commands.

Command	Function
IP	Immediate Print of displayed weight (stable or unstable).
P	Print displayed weight (stable or unstable).
CP	Continuous Print. OP ends Continuous Print.
SP	Print displayed stable weight.
SLP	Auto Print stable non-zero displayed weight.
SLZP	Auto Print stable non-zero weight and stable zero reading.
xP	Interval Print x = Print Interval (1-3600 seconds) OP ends Interval Print.
H	Enter Print Header Lines
Z	Same as pressing Zero Key
T	Same as pressing Tare Key.
xT	Establish a preset Tare value in grams. X= preset tare value in grams.
PT	Prints Tare weight stored in memory.
PM	Print current mode (weighing mode).
M	Scroll to the next enabled mode.
PU	Print current weighing unit.
U	Scroll to the next enabled unit.
OFF	Turns balance OFF.
ON	Turns balance on.
PSN	Print Serial Number.
PV	Print Version: name, software revision and LFT ON (if LFT is set ON).
x#	Set PC reference weight (x) in grams. (Must have an APW stored.)
P#	Print PC reference weight.
x%	Set % reference weight (x) in grams. (Must have reference weight stored.)
P%	Print percent reference weight.
xAW	Set Animal Weigh Level to x. (x = 3, 7, 10, 13 seconds)
PAW	Print Animal Weigh Level.
BAW	Begin Animal cycle. (Manual Mode)
CW	Clear locked weight (weight < threshold) in Manual and Semi-Auto modes.
xCO	Set Checkweighing Over Limit in grams.
xCU	Set Checkweighing Under Limit in grams.
PCO	Print Checkweighing Over Limit.
PCU	Print Checkweighing Under Limit.
PTIME	Print current time.
PDATE	Print current date.
xAW	Set AW Mode, x=A (Automatic), x=S (Semi-Automatic), x= M (Manual)

5.4.2 Connections

RS232 Interface

On the rear of the balance, the 9-pin female subminiature "D" connector COM 1, is provided for interfacing to other devices. The pin connections are shown in the illustration below.

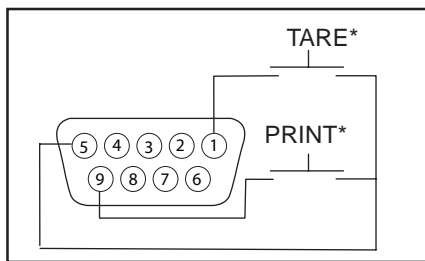

COM 1 Connector

COM1 Pin Connections

- 1 – Remote Tare
- 2 – TxD
- 3 – RxD
- 4 – DSR
- 5 – Ground
- 6 – DTR
- 7 – CTS
- 8 – RTS
- 9 – Remote Print

* External PRINT and/or TARE switches may be installed as shown in the diagram. Momentary contact switches must be used. To enable this feature, contact Ohaus Aftermarket.

A 6-pin Mini DIN connector is provided when the optional second RS232 interface is installed.

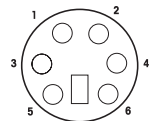

COM 2 MINI DIN Connector

COM2 Pin Connections

- 1 – TxD
- 2 – RxD
- 3 – Ground
- 4 – Vout
- 5 – reserved for future use
- 6 – No connection

USB Interface

A USB Type B connector is provided when the optional USB interface is installed.

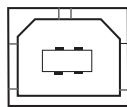

COM 2 USB Type B Connector

**LIMITED WARRANTY**

Ohaus products are warranted against defects in materials and workmanship from the date of delivery through the duration of the warranty period. During the warranty period Ohaus will repair, or, at its option, replace any component(s) that proves to be defective at no charge, provided that the product is returned, freight prepaid, to Ohaus.

This warranty does not apply if the product has been damaged by accident or misuse, exposed to radioactive or corrosive materials, has foreign material penetrating to the inside of the product, or as a result of service or modification by other than Ohaus. In lieu of a properly returned warranty registration card, the warranty period shall begin on the date of shipment to the authorized dealer. No other express or implied warranty is given by Ohaus Corporation. Ohaus Corporation shall not be liable for any consequential damages.

As warranty legislation differs from state to state and country to country, please contact Ohaus or your local Ohaus dealer for further details.











Ohaus Corporation
 19A Chapin Road
 P.O. Box 2033
 Pine Brook, NJ 07058, USA
 Tel: (973) 377-9000
 Fax: (973) 593-0359

With offices worldwide
www.ohaus.com

© Ohaus Corporation 2005, all rights reserved



* 8 0 2 5 1 1 6 1 *

P/N 80251161

Printed in China

